

OPERATOR AND ORGANIZATIONAL MAINTENANCE MANUAL
 MAINTENANCE KIT, ELECTRONIC EQUIPMENT MK-722/URC

Headquarters, Department of the Army, Washington, D. C. 20315
 10 December 1964

WARNING

Be careful when working with the 115-volt ac powerline. SERIOUS INJURY or DEATH may result from contact with terminals where this voltage is present.

This copy is a reprint which includes current pages from Changes 1 through 3.

		Paragraph	Page
CHAPTER 1 .	INTRODUCTION		
SECTION I .	General		
	Scope of manual	1-1	3
	Index of publications	1-2	3
	Forms and records	1-3	3
II .	Description and data		
	Purpose and use	1-4	3
	Technical characteristics	1-5	4
	Table of components	1-6	4
	Common names o..	1-7	5
	Description of Test Set, RadioTS-1956/URC	1-8	5
	Description of minor components	1-9	6
CHAPTER 2 .	OPERATION		
SECTION I .	Service upon receipt of equipment		
	Unpacking	2-1	12
	Checking unpacked equipment	2-2	12
II .	Operating instructions		
	Controls, indicators; and connectors	2-3	13
	Bench test procedures	2-4	15
	Preliminary starting procedures for function test set	2-5	15
	Stopping procedures for function test set	2-6	16
CHAPTER 3 .	MAINTENANCE INSTRUCTIONS		
	Scope of maintenance	3-1	17
	Tools and materials required for maintenance	3-2	17
	Preventive maintenance	3-3	17
	Daily preventive maintenance checks and services	3-4	17
	Daily preventive maintenance checks and services chart	3-5	18
	Cleaning	3-6	18
	Monthly preventive maintenance checks and services	3-7	18
	Monthly preventive maintenance checks and services chart	3-8	18
	Preservation	3-9	19
	Quarterly preventive maintenance checks and services	3-10	19
	Quarterly preventive maintenance checks and services chart	3-11	19

	Paragraph	Page
CHAPTER 4. SHIPMENT, LIMITED STORAGE, AND DEMOLITION TO PREVENT ENEMY USE		
SECTION I. Shipment and limited storage		
Disassembly of equipment	4-1	20
Repackaging for shipment and limited storage	4-2	20
SECTION II. Demolition of materiel to prevent enemy use		
Authority for demolition	4-3	20
Methods of destruction	4-4	20
APPENDIX I. REFERENCES		22
II. MAINTENANCE ALLOCATION		23
III. BASIC ISSUE ITEMS LIST		27

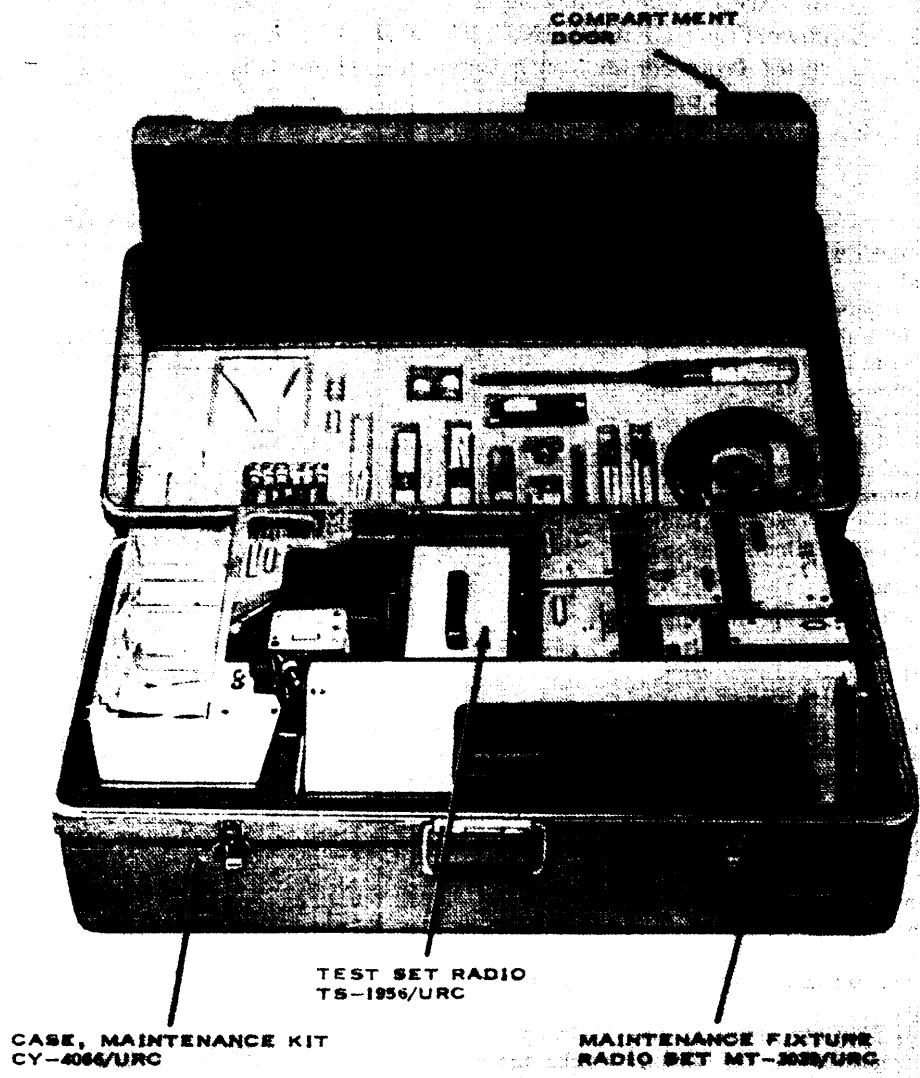

TM 11-6625-623-12-1

Figure 1-1. Maintenance Kit, Electronic Equipment MK-722/URC.

CHANGE }
No. 3 }

HEADQUARTERS
DEPARTMENT OF THE ARMY
WASHINGTON, DC, 31 August 1977

**Operator's and
Organizational Maintenance Manual
(Including Repair Parts and Special Tool Lists)
MAINTENANCE KIT, ELECTRONIC EQUIPMENT MK-722/URC
(NSN 5999-00-757-7042)**

TM 11-6625-623-12 10 December 1964, is changed as follows:
Title is changed as shown above.
Add Radiation Warning inside front cover.

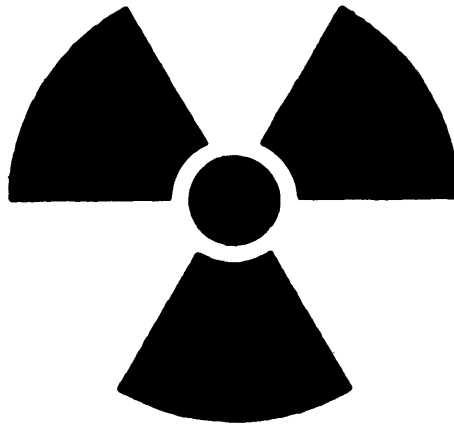

STD-RW-2

Connector Ra226 24uCi 5935-811-1382

Radiation Hazard Information: The following radiation hazard information must be read and understood by all personnel before operating or repairing Electronic Equipment Maintenance Kit MK-722/URC. Hazardous radioactive materials are present in the above listed component.

The components are potentially hazardous when broken. See qualified medical personnel and the local Radiological Protection Officer (RPO) immediately if you are exposed to or cut by broken components. First aid instructions are contained in TB 43-0122, and AR 755-15.

NEVER place radioactive components in your pocket.

Use extreme care NOT to break radioactive components while handling them.

NEVER remove radioactive components from cartons until you are ready to use them.

If any of these components are broken, notify the local RPO immediately. The RPO will survey the immediate area for radiological contamination and will supervise the removal of broken components.

The above listed radioactive components will *not* be repaired or disassembled.

Disposal of broken, unserviceable, or unwanted radioactive components will be accomplished in accordance with the instructions in AR 755-15.

By Order of the Secretary of the Army:

BERNARD W. ROGERS
General, *United States Army*
Chief of Staff

Official:

PAUL T. SMITH
Major *General, United States Army*
The Adjutant General

Distribution:

To be distributed in accordance with DA Form 12-36A, Organizational maintenance requirements for MK-722/URC.

CHANGE }
No. 2 }

HEADQUARTERS,
DEPARTMENT OF THE ARMY
WASHINGTON, D.C. 14 May 1974

**Organizational Maintenance Manual
(Including Repair Parts and Special Tool List)
MAINTENANCE KIT, ELECTRONIC EQUIPMENT
MK-722/URC**

TM 11-6625-623-12, 10 December 1964, is changed as follows:

Page 3. Delete paragraph 1-2 and substitute:

1-2. Indexes of Publications

a. *DA Pam 310-4.* Refer to the latest issue of DA Pam 310-4 to determine whether there are new editions, changes, or additional publications pertaining to the equipment.

b. *DA Pam 310-7.* Refer to DA Pam 310-7 to determine whether there are modification work orders (MWO'S) pertaining to the equipment. Delete paragraph 1-3 and substitute:

1-3. Forms and Records

a. *Reports of Maintenance and Unsatisfactory Equipment.* Maintenance forms, records, and reports which are to be used by maintenance personnel at all maintenance levels are listed in and prescribed by TM 38-750.

b. *Report of Packaging and Handling Deficiencies.* Fill out and forward DD Form 6 (Report of

Packaging and Handling Deficiencies) as prescribed in AR 700-58/NAVSUP PUB 378/AFR 71-4/MCO P4030.29, and DSAR 4145.8.

c. *Discrepancy in Shipment Report (DISREP) (SF 361).* Fill out and forward Discrepancy in Shipment Report (DISREP) (SF 361) as Prescribed in AR 55-38/NAVSUPINST 4610.33/AFM 75-18/MCO P4610.19A, and DSAR 4500.15. After paragraph 1-3 add:

1-3.1. Reporting of Equipment Publication Improvements

The reporting of errors, omissions, and recommendations for improving this publication by the individual user is encouraged. Reports should be submitted on DA Form 2028 (Recommended Changes to Publications and Blank Forms) and forwarded direct to Commander, US Army Electronics Command, ATTN: AMSEL-MA-C, Fort Monmouth, NJ 07703.

Page 4. Delete paragraph 1-6 and substitute:

1-6. Items Comprising an Operable Equipment

FNSV	Qty	Nomenclature, part No., and alt. code	Fig. No.	Dimensions (in.)			Weight (lb.)
				Height	Depth	Width	
6625-082-4275		Maintenance Kit, Electronic Equipment MK-722/URC consisting of: NOTE The part number is followed by the applicable 5-digit Federal supply code for manufacturers (FSCM) identified in SB 708-42 and used to identify manufacturer, distributor, or Government Agency, etc.	1-1				
5935-683-7892	1	Adapter, Cable UG-274B/U					
5935-681-5013	1	Adapter, Connector UG-491B/U	1-4				0.06
5935-280-1454	1	Adapter, Connector UG-914/U	1-4				0.06
5935-709-5709	2	Adapter, Connector: 1645; 05276					
5120-288-7786	1	Alignment Tool, Electronic Equipment: 8606; 72653					
5120-516-3108	1	Alignment Tool, Electronic Equipment: 024-0309-00; 95104					
5821-019-6317	1	Attenuator, Fixed, CN-1066/URC: 548-3522-002; 95104		1	3.125	0.937	
5995-985-8170	1	Cable Assembly, RF, CG-2549A/U: plug UG-88E/U on one end; 75, 37942; 548-3489-002, 95104	1-4				0.2
5995-985-8199	1	Cable Assembly, RF, CG-2727/U	1-4				0.2
5995-252-5838	6	Cable Assembly, RF, CG-2730/U; plug UG-88E/U on each end; 546-7321-002, 95104	1-4				0.0625
5995-985-8169	1	Cable Assembly, RF, CG-3126/U: plug UG-88E/U on one end; other end, plug telephone PJ068), 548-3490-002; 95104	1-4				0.2
5995-985-8173	1	Cable Assembly, Power, Electrical, CX-9009/URC: (plug 7429; 83315 on one end; plug 4725-3; 24446 on other end), 548-3490-002; 95104	1-4				0.312
6625-019-6315	1	Detector, Radio frequency, DT-278/URC: 548-3533-002; 95104	1-6	2 5/16	1	15/16	0.125
5821-081-3957	1	Dial Scale: 548-3530-002; 95104	1-6				0.02
5821-019-6315	1	Dummy Load, Electrical, DA-34/URC: 549-0989-003; 95104	1-6	3	1 5/16	1 1/16	0.125
6625-019-6301	1	Extender, Module, MX-4887/URC: 548-3452-00; 95104	1-3	13	8 1/2	12 23/32	0.936
6625-019-6311	1	Extender, Module, MX-4888/URC: 548-3463-004; 95104	1-3	5 15/16	6 15/16	2 15/16	0.688
6625-019-6303	1	Extender, Module, MX-4889/URC: 548-3501-004, 95104	1-3	6 15/16	1 1/4	1 1/2	0.688
6625-019-6304	1	Extender, Module, MX-4890/URC: 548-3502-004; 95104	1-3	4 1/4	6 15/16	1 7/16	0.688

FSV	Qty	Nomenclature, part No., and infr code	Fig. No.	Dimensions (in.)			Weight (lb.)
				Height	Depth	Width	
6625-019-6310	1	Extender, Module, MX-4891/URC: 548-3461-004; 95104	1-3	7 5/16	4 9/16	2 15/16	0.688
6625-083-7311	1	Extender, Module, MX-4892/URC: 548-3505-00; 95104	1-3	4 1/16	7 5/16	2 15/16	0.688
6625-019-6305	1	Extender, Module, MX-4893/URC: 548-3543-004; 95104	1-3	6 15/16	4 5/16	1 7/16	0.3115
6625-019-6306	1	Extender, Module, MX-4894/URC: 548-3455-004; 95104	1-3	5 7/8	3	2 7/16	0.375
6625-019-6309	1	Extender, Module, MX-4895/URC: 548-3459-004; 95104	1-3	6 15/16	5 15/16	2 15/16	0.625
5821-019-6290	1	Extractor, Module: 546-6463-002; 95104					
5120-763-1262	2	Extractor, Electron Tube: SK604A; 06980					
6625-795-0522	1	Frame, Actuator: 548-8014-003; 95104	1-6				0.125
5120-293-0195	1	Key: S060-4-6CDPL; 29398					
5120-223-6995	1	Key: S096-8-6CDPL; 29398					
5120-995-7192	1	Key: Socket Head Screw: AS096; 29398					
6625-019-6318		Maintenance Fixture, Radio Set MT-3039/URC: 549-0990- 004; 95104	1-5	21 3/4	10 9/16	2 3/16	2.0
5355-062-0949	1	Pointer, Dial: 549-0974-002; 95104	1-6				0.001
6625-061-3649	1	Prod, Test: 548-3484-002; 95104	1-6				0.0625
6625-019-6312	1	Prod, Test: 548-3486-002; 95104	1-6				0.0625
6625-061-3648	1	Prod, Test: 548-3499-002; 95104	1-6				0.05
5120-542-3438	1	Screwdriver: 130291NSHK; 03705	1-6				0.25
6625-069-2690	1	Socket, Electron Tube: TVS7; 05276					
6625-891-5128	1	Socket, Electron Tube; TVS9 05276					
6625-965-0188		Test Set TS-1956/URC: 761-4984- 001; 95104 which includes:	1-1	8 3/4	5 1/2	9 1/8	5.0
6625-965-0186	1	Lead, Test, CX-9010/URC: 549-1005-002; 95104	1-4				0.03
6625-965-0181	1	Lead, Test, CX-9011/URC: 549-1006-003; 95104	1-4				0.03
6625-965-0182	1	Lead, Test, CX-9012/URC: 549-1007-003; 95104	1-4				0.03
6625-965-0183	1	Lead, Test, CX-9013/URC: 423-0241-00; 95104	1-4				0.03
6625-965-0184	1	Lead, Test, CX-9014/URC: 1009-003; 95104	1-4				0.03
6625-965-0187	1	Lead, Test, CX-9015/URC: 549-1010-003; 95104	1-4				0.03
5120-060-6423	1	Tool Tuning: 547-2796-002; 95104	1-6				0.02
6625-019-6314	1	Voltage Divider TS-1954/URC: 548-3525-002; 95104	1-6	3 1/8	1	15/16	0.063
6625-019-6313	1	Voltage Divider TS-1955/URC: 548-3528-002; 95104	1-6	3 1/8	1	15/16	0.063

APPENDIX III BASIC ISSUE ITEMS LIST (BILL) AND ITEMS TROOP INSTALLED OR AUTHORIZED LIST (ITIAL)

Section I. INTRODUCTION

1. Scope.

This appendix lists only basic issue items required by the crew/operator for installation, operation, and maintenance of Maintenance Kit, Electronic Equipment MK-722/URC.

2. General

This Basic Issue Items and Items Troop Installed or Authorized List is divided into the following sections:

a. Basic Issue Items List - Section II. A list, in alphabetical sequence, of items which are furnished with, and which must be turned in with the end item.

b. Items Troop Installed or Authorized List - Section III. Not applicable.

3. Explanation of Columns

The following provides an explanation of columns found in the tabular listings:

a. Illustration. Not applicable.

b. Federal Stock Number. Indicates the Federal stock number assigned to the item and will be used for requisitioning purposes.

c. Part Number. Indicates the primary number

used by the manufacturer (individual, company, firm, corporation, or Government activity), which controls the design and characteristics of the item by means of its engineering drawings, specifications standards, and inspection requirements, to identify an item or range of items.

d. Federal Supply Code for Manufacturer (FSCM). The FSCM is a 5-digit numeric code used to identify the manufacturer, distributor, or Government agency, etc. and is identified in SB 708-42.

e. Description. Indicates the Federal item name and a minimum description required to identify the item.

f. Unit of Measure (U/M). Indicates the standard of basic quantity of the listed item as used in performing the actual maintenance function. This measure is expressed by a two-character alphabetical abbreviation, (e.g., ea, in., pr, etc.). When the unit of measure differs from the unit of issue, the lowest unit of issue that will satisfy the required units of measure will be requisitioned.

g. Quantity Furnished with Equipment (Basic Issue Item Only). Indicates the quantity of the basic issue item furnished with the equipment.

Section II. BASIC ISSUE ITEMS LIST

(1) Illustration		(2) Federal stock number	(3) Part number	(4) FSCM	(5) Description Usable on code	(6) Unit of meas	(7) Qty furn with equip
(A) Fig. no.	(B) Item no.						
		6625-766-3677	SK625200	74284	CASE, MAINTENANCE KIT	EA	1
		8105-063-5060	104N4X6	20344	CY-4066/URC BAG, COTTON DUCK	EA	1

By Order of the Secretary of the Army:

CREIGHTON W. ABRAMS
General, United States Army
Chief of Staff

Official:

VERNE L. BOWERS
Major General, United States Army
The Adjutant General

Distribution:

To be distributed in accordance with DA Form 12-36A (qty rqr block No. 1080), Organizational maintenance requirements for MK-722/URC.

CHANGE }
No. 1

HEADQUARTERS
DEPARTMENT OF THE ARMY
WASHINGTON D.C., 2 March 1966

Organizational Maintenance Manual (Including Repair Parts and Special Tool Lists)

MAINTENANCE KIT, ELECTRONIC EQUIPMENT MK-722/URC

TM 11-6625-623-12, 10 December 1964, is changed as follows:
The title of the manual is changed as shown above.

Page 3, paragraph 1-2. Delete paragraph 1-2 and substitute:

1-2. Index of Publications

Refer to the latest issue of DA Pam 310-4 to determine whether there are new editions, changes, or additional publications pertaining to the equipment. DA Pam 310-4 is a current index of technical manuals, technical bulletins, supply manuals (types 7, 8, and 9), supply bulletins, lubrication orders, and modification work orders available through publications supply channels. The index lists the individual parts (-10, -20, -35P, etc.) and the latest changes to and revisions of each equipment publication.

Paragraph 1-3. Delete subparagraph *c* and substitute:

c. Reporting of Equipment Manual Improvements. The direct reporting, by the individual user, of errors, omissions, and recommendations for improving this equipment manual is authorized and encouraged. DA Form 2028 (Recommended Changes to DA Publications) will be used for reporting these improvements. This form may be completed using pencil, pen, or typewriter and forwarded direct to Commanding General, U.S. Army Electronics Command, ATTN: AMSEL MR-(NMP)-MA, Fort Monmouth, New Jersey, 07703.

Page 28, appendix III. Delete section II and substitute:

SECTION II. OPERATOR'S FUNCTIONAL PARTS LIST

FEDERAL STOCK NUMBER	DESIGNATION BY MODEL	DESCRIPTION	UNIT OF ISSUE	EXP	QTY AUTH	ILLUSTRATION	
						FIGURE NO.	ITEM NO.
6625-082-4275		MAINTENANCE KIT, ELECTRONIC EQUIPMENT MK-722/URC: provides module extenders, adapter cables, and special tools so that adjustments may be performed for the Radio Sets AN/ARC-102 and AN/MRC-95. A complete operational check is provided when used in conjunction w/ Test Harness AN/URM-157; Collins Radio p/n 522-3401.005		NX			
ORD THRU AGC		TECHNICAL MANUAL TM 11-6625-623-12 NOTE: For technical manuals the quantity authorized indicates the number of copies packed with the equipment at the time of procurement. It represents the maximum quantity authorized. Where a number of these equipments are concentrated in a small area, the quantity on hand may be reduced to practical levels. Excess publications must be returned to publication supply centers through AG channels.			2		
5935-683-7892		ADAPTER, CABLE UG-274B/U			1		
5935-549-1154		ADAPTER, CONNECTOR UG-491B/U: 1 cont; 2 connector mating ends; MIL type MS35176			1		
5935-280-1454		ADAPTER, CONNECTOR UG-914/U:			1		
5935-709-5709		ADAPTER, CONNECTOR: Pomona Elec p/n 1645			2		
5120-288-7786		ALIGNMENT TOOL, ELECTRONIC EQUIPMENT: wrench type; hexagon socket; 5.123 in lg o/a; G C Elec p/n 8606			1		
5120-516-3108		ALIGNMENT TOOL, ELECTRONIC EQUIPMENT: wrench type; slot type; 5.999 in lg o/a; JACO PROD p/n 024-0309-00; Collins Radio p/n 024-0309-00			1		
5821-019-6317		ATTENUATOR, FIXED, CN-1066/URC: 3.125 in lg X 0.937 in wd X 1 in h o/a; Collins Radio p/n 548-3522-002		NX	1		
8105-063-5060		BAG, COTTON DUCK: drawstring enclosure; 6 in lg X 4 in wd; National Bag Co p/n 104N4X6			1		
5995-985-8170		CABLE ASSEMBLY, RF, CG-2549A/U: 4 ft 4 in; plug UG-88E/U on one end; plug, telephone P R Mallory p/n 75, other end; Collins Radio p/n 548-3489-002			1		
5995-985-8199		CABLE ASSEMBLY, RF CG-2727/U: 5 ft			1		

FEDERAL STOCK NUMBER	DESIGNATION BY MODEL	DESCRIPTION	UNIT OF ISSUE	FXP	QTY AUTH	ILLUSTRATION	
						FIGURE NO.	ITEM NO.
		MK-722/URC (continued)					
5995-985-7888		CABLE ASSEMBLY, RF CG-2730/U (4 in): plug UG-88E/U on ea end; Collins Radio p/n 546-7321-002			6		
5995-985-8169		CABLE ASSEMBLY, RF, CG-3126/U: 4 ft 4-1/2 in; plug UG-88E/U on one end; other end, plug telephone PJ068; Collins Radio p/n 548-3490-002			1		
5995-985-8173		CABLE ASSEMBLY, POWER, ELECTRICAL, CX-9009/URC: plug, Hubbell p/n 7429 on one end, plug, GE p/n 4725-3 other end; Collins Radio p/n 548-3539-002			1		
6625-766-3677		CASE, MAINTENANCE KIT CY-4066/URC: provides for storage and transit of maintenance kit, Electronic Equipment MK-722/URC; Skydyne p/n SK625200			1		
6625-019-6316		DETECTOR, RADIOFREQUENCY, DT-278/URC: used in neutralizing the driver circuits of the RF Translator module; Collins Radio p/n 548-3533-002		NX	1		
5821-081-3957		DIAL, SCALE: 0 to 90 cw; 2 in dia X 0.188 in thk; Collins Radio p/n 548-3530-002			1		
5821-019-6315		DUMMY LOAD, ELECTRICAL, DA-340/URC: provides RF Translator module w/ dummy load for test purposes; Collins Radio p/n 549-0989-003		NX	1		
6625-019-6301		EXTENDER, MODULE, MX-4887/URC: extends the RF Translator module of the RT-698/ARC-102 for testing; Collins Radio p/n 548-3452-00		NX	1		
6625-019-6311		EXTENDER, MODULE MX-4888/URC: extends the RF oscillator module of the RT-698/ARC-102 for testing; Collins Radio p/n 548-3463-004		NX	1		
6625-019-6303		EXTENDER, MODULE, MX-4889/URC: extends frequency stablizer module of the Receiver-Transmitter, Radio RT-698/ARC-102 for testing; Collins Radio p/n 548-3501-004		NX	1		
6625-019-6304		EXTENDER, MODULE MX-4890/URC: extends frequency divider module of the Receiver-Transmitter, Radio RT-698/ARC-102 for testing; Collins Radio p/n 548-3502-004		NX	1		

FEDERAL STOCK NUMBER	DESIGNATION BY MODEL	DESCRIPTION	UNIT OF ISSUE	EXP	QTY AUTH	ILLUSTRATION	
						FIGURE NO.	ITEM NO
		MK-722/URC (continued)					
6625-019-6310		EXTENDER, MODULE, MX-4891/URC: extends the AM/AUDIO module of RT-698/ARC-102 for testing; Collins Radio p/n 548-3461-004		NX	1		
6625-083-7311		EXTENDER, MODULE MX-4892/URC: extends the IF Translator module of RT-698/ARC-102 for testing; Collins Radio p/n 548-3505-00		NX	1		
6625-019-6305		EXTENDER MODULE MX-4893/URC: extends the Amplifier module of RT-698/ARC-102 for testing; Collins Radio p/n 548-3543-004		NX	1		
6625-019-6306		EXTENDER, MODULE, MX-4894/URC: extends the low voltage power supply of RT-698/ARC-102 for testing; Collins Radio p/n 548-3455-004		NX	1		
6625-019-6309		EXTENDER, MODULE MX-4895/URC: extends the Frequency Stabilizer module of RT-698/ARC-102 for testing; Collins Radio p/n 548-3459-004		NX	1		
5821-019-6290		EXTRACTOR, MODULE: 0.828 in X 2.750 in X 5.375 in o/a; Collins Radio p/n 546-6463-002			1		
5120-763-1262		EXTRACTOR, ELECTRON TUBE: tong type Eitel-McCullough p/n SK604A			2		
6625-795-0522		FRAME, ACTUATOR: al; 5.063 in X 4.000 in X 2.016 in o/a; Collins Radio p/n 548-8014-003			1		
5120-293-0195		KEY: Bristol Co p/n S060-4-6CDPL			1		
5120-223-6995		KEY: Bristol Co p/n S096-8-6CDPL			1		
5120-995-7192		KEY, SOCKET HEAD SCREW: splined type, 6 flutes; 0.940 in dia; Bristol Co Read Instr Div p/n AS096			1		
6625-019-6318		MAINTENANCE FIXTURE, RADIO SET MT-3039/URC: provides facilities for elevating RT-698/ARC-102 during test to allow air to be exhausted from bottom; Collins Radio p/n 549-0990-004		NX	1		
5355-062-0949		POINTER, DIAL: al; 0.687 in lg X 0.250 in wd X 0.485 in h; Collins Radio p/n 549-0974-002			1		
6625-061-3649		PROD, TEST: black plastic handle 3 in lg; 5.300 in lg X 0.500 in wd X 0.906 in h o/a; Collins Radio p/n 548-3484-002			1		

FEDERAL STOCK NUMBER	DESIGNATION BY MODEL	DESCRIPTION	UNIT OF ISSUE	FXP	QTY AUTH	ILLUSTRATION	
						FIGURE NO.	ITEM NO.
		MK-722/URC (continued)					
6625-019-6312		PROD, TEST: red plastic 3 in lg; incl capacitor; 6.096 in lg X 0.500 in wd X 0.968 in h o/a; Collins Radio p/n 548-3486-002			1		
6625-061-3648		PROD, TEST: red plastic handle, 3 in lg; cable attached w/ jack tip; 4.437 in lg X 0.375 in dia o/a; Collins Radio p/n 548-3499-002			1		
5120-965-0287		SCREWDRIIVER: Apex Machine and Tool Co p/n 130291NSHK			1		
6625-069-2690		SOCKET, ELECTRON TUBE: 7 cont; 1.390 in h X 0.905 in dia; Pomona Elec p/n TVS7			1		
6625-891-5128		SOCKET, ELECTRON TUBE: 9 cont; Pomona Elec p/n TVS9			1		
6625-965-0188		TEST SET TS-1956/URC: 9.125 in lg X 5.5 in wd X 8.812 in h; Collins Radio p/n 761-4984-001		NX	1		
6625-965-0186		LEAD, TEST, CX-9010/URC: provides grounding facilities for the Test Set, Radio TS-1956/URC; Collins Radio p/n 549-1005-002			1		
6625-965-0181		LEAD, TEST CX-9011/URC: provides interconnecting facilities between the Receiver-Transmitter, Radio RT-698/ARC-102 and Test Set, Radio TS-1956/URC; Collins Radio p/n 549-1006-003			1		
6625-965-0182		LEAD, TEST CX-9012/URC: provides interconnecting facilities between the Receiver-Transmitter, Radio RT-698/ARC-102 and Test Set, Radio TS-1956/URC; Collins Radio p/n 549-1007-003			1		
6625-965-0183		LEAD, TEST, CX-9013/URC: provides interconnecting facilities between Receiver-Transmitter, Radio RT-698/ARC-102 and Test Set, Radio TS-1956/URC; Collins Radio p/n 423-0241-00			1		
6625-965-0184		LEAD, TEST, CX-9014/URC: provides interconnecting facilities between the Receiver-Transmitter, Radio RT-698/ARC-102 and Test Set, Radio TS-1956/URC; Collins Radio p/n 1009-003			1		
6625-965-0187		LEAD, TEST CX-9015/URC: provides interconnecting facilities between the Receiver-Transmitter, Radio RT-698/ARC-102 and the Test Set, Radio TS-1956/URC; Collins Radio p/n 549-1010-003			1		

FEDERAL STOCK NUMBER	DESIGNATION BY MODEL	DESCRIPTION	UNIT OF ISSUE	EXP	QTY AUTH	ILLUSTRATION	
						FIGURE NO.	ITEM NO.
5120-060-6423		MK-722/URC (continued)			1		
6625-019-6314		TOOL, TUNING: Collins Radio p/n 547-2796-002			1		
6625-019-6313		VOLTAGE DIVIDER TS-1954/URC: reduces the RF output voltage of the RT-698/ARC-102 from approx 80 v to approx 2.5 v; Collins Radio p/n 548-3525-002		NX	1		
		VOLTAGE DIVIDER TS-1955/URC: reduces RF output voltage of RT-698/ARC-102 from approx 80 v to approx 2.5 v; Collins Radio p/n 548-3528-002		NX	1		
		RUNNING SPARE ITEMS					
		NO PARTS AUTHORIZED FOR STOCKAGE AT OPERATOR'S LEVEL					

APPENDIX IV

ORGANIZATIONAL REPAIR PARTS LIST

Section I. INTRODUCTION

A4-1. General

a. This appendix lists the quantities of repair parts authorized for organizational maintenance and constitutes a basis of requisitioning when the major item of equipment is authorized to the organization. These equipments are issued on the basis of allowances prescribed in equipment authorization tables and other documents which are a basis of requisitioning.

b. Columns areas follows:

- (1) *Federal stock number.* This column lists the n-digit stock number.
- (2) *Designation by model.* Not used.
- (3) *Description.* Nomenclature or the standard item name and brief identifying data for each item are listed in this column. When requisitioning, enter the nomenclature and description.
- (4) *Unit of issue.* The unit of issue is each unless otherwise indicated and is the supply term by which the individual item is counted for procurement, storage, requisitioning, allowances, and issue purposes.
- (5) *Expendability.* Nonexpendable items are indicated by NX. Expendable items are not annotated.
- (6) *Quantity incorporated in unit.* This column lists the quantity of each part found in a given assembly, component, or equipment.
- (7) *Organizational.* The quantities indicated in this column are maximum levels of repair parts authorized to be kept on hand by units performing organizational maintenance. The quantities are based on 100 equipments to be maintained for a 15-day period.
- (8) *Illustration.* The "Item No." column lists the reference designations that appear on the part in the equipment. These same

designations are also used on any illustrations of the equipment.

A4-2. Parts for Maintenance

When this equipment is used by Signal service organizations organic to the theater headquarters or communication zones to provide theater communications, those repair parts authorized up to and including general support are authorized for stockage by the organization operating this equipment.

A4-3. Additional Repair Parts Authorization

An asterisk (*) indicates that an item is not authorized for stockage but if required, may be requisitioned for immediate use only.

A4-4. Maintenance Float Requirements

Supply Bulletin SB 11-244 is the authorizing document for maintenance float. It authorizes a maximum number of major components which are installed in Army aircraft and states in part:

"A careful review will be made by the responsible maintenance officer to limit maximum percentage of maintenance float to only those items that exhibit high failure rates. Items authorized for stockage as maintenance float will be included on the theatre or installation authorized stockage list in accordance with AR 711-16, coded to indicate that stockage is for maintenance float. In the case of avionics maintenance float, the field maintenance officer is encouraged to locate the float at Army airfields in order to obtain maximum utilization.

A4-5. Requisitioning Information

a. The allowance factors are based on 100 equipment. In order to determine the number of parts

authorized for the specific number of equipments supported, the following formula will be used and carried out to two decimal places.'

Specific number of equipments supported

$$\times \frac{\text{allowance factor}}{100}$$

= number of parts authorized.

b. Fractional values obtained from above computation will be rounded to whole numbers as follows :

- (1) When the total number of parts authorized is less than one, the quantity authorized will be one.
- (2) For all values above one, fractional values below 0.5 will revert to the next lower number, functional values of 0.5 or larger

will advance to the next higher whole number.

c. The number of parts authorized determined after application of a and b above, represent one prescribed load for a 15-day period. The items and computed quantities thereof must be on hand or on order at all times.

d. Major commanderds will determine the number of prescribed loads organizational units will carry. Units and organizations authorized additional prescribed loads will utilize the formula explained in a above but will multiply the number of equipments supported by the number of authorized prescribed loads before completing the formula. Fractional values will be rounded to whole numbers as described above.

SECTION II. ORGANIZATIONAL FUNCTIONAL PARTS LIST

FEDERAL STOCK NUMBER	DESIGNATION BY MODEL	DESCRIPTION	UNIT OF ISSUE	EXP	QTY IN UNIT	ORGANIZATIONAL	ILLUSTRATION	
							FIGURE NO.	ITEM NO.
6625-082-4275		MAINTENANCE KIT, ELECTRONIC EQUIPMENT MK-722/URC: provides module extenders, adapter cables and special tools for tests, adjustments, switching and calibration of AN/ARC-102 and AN/MRC-95		NX				
5935-603-1892		ADAPTER, CONNECTOR, UG-274E/U			1	*		A17
5935-549-1154		ADAPTER, CONNECTOR, UG-491E/U			1	*		A19
5935-280-1454		ADAPTER, CONNECTOR, UG-914/U			1	*		A18
5935-709-5709		ADAPTER, CONNECTOR: bayonet lock pin type, straight shape; 2 contacts, 2 connector mating ends; Pomona Elec Co Inc p/n 1645 or General Radio Co p/n 2740BJ			2	*		
6625-069-2690		ADAPTER, TEST: connects to item to be tested by 7 pin plug-in socket; plastic body 1.500 in lg and 1.000 in dia o/a; Pomona Elec Co Inc p/n TVS-7			1	*		
6625-891-5128		ADAPTER, TEST: connects to item to be tested by integral connector; test socket accommodates 9 pin miniature tube; plastic body 1-1/16 in dia and 1-1/16 in h o/a; Pomona Elec Co Inc p/n TVS-9			1	*		
5120-060-6423		ALIGNMENT TOOL, ELECTRONIC EQUIPMENT: screwdriver type with nonmetallic screwdriver tip on each end; plastic body; Collins Radio Co p/n 547-2796-002			1	*		
5120-288-7786		ALIGNMENT TOOL, ELECTRONIC EQUIPMENT: combination screwdriver and wrench type; nonmetallic screwdriver tip on one end and Allen hexagonal socket, 0.100 in across flats, on other end; plastic body; G.C. Elec Mfg Co p/n 8606			1	*		
5120-516-3108		ALIGNMENT TOOL, ELECTRONIC EQUIPMENT: screwdriver type with plastic body; metallic screwdriver tip on each end; JACO Products Co p/n 024-0309-00			1	*		
5821-019-6317		ATTENUATOR, FIXED, CN-1066/URC		NX	1	*		
6625-019-6316		DETECTOR, RADIOFREQUENCY, DT-278/URC		NX	1	*		
5821-081-3957		DIAL, SCALE: range 0 to 90 cw; graduated in 100 scale divisions; Collins Radio Co p/n 548-3530-002			1	*		

FEDERAL STOCK NUMBER	DESIGNATION BY MODEL	DESCRIPTION	UNIT OF ISSUE	EXP	QTY IN UNIT	ORGANIZATIONAL	ILLUSTRATION	
							FIGURE NO.	ITEM NO.
		MK-722/URC (continued)						
5821-019-6315		DUMMY LOAD, ELECTRICAL, DA-340/URC		NX	1	*		
6625-019-6301		EXTENDER, MODULE, MX-4887/URC (MAINTENANCE FLOAT ITEM)		NX	1	*		
6625-019-6311		EXTENDER, MODULE, MX-4888/URC (MAINTENANCE FLOAT ITEM)		NX	1	*		
6625-019-6303		EXTENDER, MODULE, MX-4889/URC (MAINTENANCE FLOAT ITEM)		NX	1	*		
6625-019-6304		EXTENDER, MODULE, MX-4890/URC (MAINTENANCE FLOAT ITEM)		NX	1	*		
6625-019-6310		EXTENDER, MODULE, MX-4891/URC (MAINTENANCE FLOAT ITEM)		NX	1	*		
6625-083-7311		EXTENDER, MODULE, MX-4892/URC (MAINTENANCE FLOAT ITEM)		NX	1	*		
6625-019-6305		EXTENDER, MODULE, MX-4893/URC (MAINTENANCE FLOAT ITEM)		NX	1	*		
6625-019-6306		EXTENDER, MODULE, MX-4894/URC (MAINTENANCE FLOAT ITEM)		NX	1	*		
6625-019-6309		EXTENDER, MODULE, MX-4895/URC (MAINTENANCE FLOAT ITEM)		NX	1	*		
5120-763-1262		EXTRACTOR, ELECTRON TUBE: tong type; designed for type 3CX100A5 and 4CX250B tubes; Eitel-McCullough Inc p/n SK604A			2	*		
5821-019-6290		EXTRACTOR, MODULE: dimensions 0.828 in X 2.750 in X 5.375 in o/a; Collins Radio Co p/n 546-6463-002			1	*		
5120-223-6995		KEY, SOCKET HEADSCREW: L shaped; multiple spline type, size no. 8; Bristol Co p/n S096-8-6CDPL			1	*		
5120-293-0195		KEY, SOCKET HEADSCREW: L shaped; multiple spline type, size no. 4; Bristol Co p/n S060-4-6CDPL			1	*		
5120-995-7192		KEY, SOCKET HEADSCREW: screwdriver type handle; multiple spline type blade, size no. 8; Bristol Co, Read Ind Ins Div p/n AS096			1	*		
5355-062-0949		POINTER, DIAL: aluminum with chromate finish; 0.687 in lg, 0.250 in wd and 0.485 in h o/a; Collins Radio Co p/n 549-0974-002			1	*		

FEDERAL STOCK NUMBER	DESIGNATION BY MODEL	DESCRIPTION	UNIT OF ISSUE	EXP	QTY IN UNIT	ORGANIZATIONAL	ILLUSTRATION	
							FIGURE NO.	ITEM NO.
6625-019-6312		MK-722/URC (continued) PROD, TEST: test probe no. 1; red plastic handle with replaceable phone tip on one end and bayonet locking type connector on other end; Collins Radio Co p/n 548-3486-002			1	*		
6625-061-3649		PROD, TEST: test probe no. 2; black plastic handle with replaceable phone tip on one end and bayonet locking type connector on other end; Collins Radio Co p/n 548-3484-002			1	*		
6625-061-3648		PROD, TEST: test probe no. 3; brown plastic handle with replaceable phone tip; Collins Radio Co p/n 548-3499-002			1	*		
5120-965-0287		SCREWDRIVER, CROSS TIP: Phillips no. 2 size tip; plastic handle with blade 9 in lg; Apex Machine and Tool Co p/n 1302-9INSHK			1	*		
6625-019-6314		VOLTAGE DIVIDER TS-1954/URC		NX	1	*		
6625-019-6313		VOLTAGE DIVIDER TS-1955/URC		NX	1	*		
		TEST SET TS-1956/URC (MAINTENANCE FLOAT ITEM)						
5920-043-2641		FUSE, CARTRIDGE: 1/4 amp, 250 volts maximum; glass body with ferrule type terminals; 1.250 in lg and 0.250 in dia o/a; MIL type FO2GR250A			1	5.7		F1
5355-994-5881		INSERT, KNOB: used on knob per Collins Radio Co p/n 544-0779-004; aluminum; 0.450 in dia and 0.531 in lg o/a; Collins Radio Co 544-0778-004			4	*		
5355-778-4967		KNOB: setscrew type with 6-32 threaded hole, without setscrew; phenolic body with pointer shape; 1.125 in lg, 0.938 in wd, and 0.750 in thk o/a; Collins Radio Co p/n 544-0779-004			4	*		
6240-723-3378		LAMP, GLOW: neon gas filled; reference drawing group number 7, type T-2; MIL type MS25252-NE2J			1	4.8		
6625-965-0186		LEAD, TEST, CX-9010/URC			1	*		W1

FEDERAL STOCK NUMBER	DESIGNATION BY MODEL	DESCRIPTION	UNIT OF ISSUE	EXP	QTY IN UNIT	ORGAN- IZATIONAL	ILLUSTRATION	
							FIGURE NO.	ITEM NO.
		MK-722/URC (continued)						
6625-965-0181		LEAD, TEST, CX-9011/URC			1	*		W2
6625-965-0182		LEAD, TEST, CX-9012/URC			1	*		W3
6625-965-0183		LEAD, TEST, CX-9013/URC			1	*		W4
6625-965-0184		LEAD, TEST, CX-9014/URC			1	*		W5
6625-965-0187		LEAD, TEST, CX-9015/URC			1	*		W6
6210-892-5460		LENS, INDICATOR LIGHT: clear red plastic lens; includes lens holder with 5/16-32 external thread; 1 in lg and 7/16 in dia o/a; Dialight Corp p/n 137-931			1	*		

By Order of the Secretary of the Army:

HAROLD K. JOHNSON,
General, United States Army,
Chief of Staff.

Official:

J. C. LAMBERT,
Major General, United States Army,
The Adjutant General.

Distribution:

To be distributed in accordance with DA Form 12-36, Unclassified requirements for Direct and General Support Maintenance for the CV-2A, CV-2B, CV-7A, OV-1A, OV-1B, OV-1C, U-1A, U-6A, U-8F, U-10A, CH-21B, CH-21C, CH-34C, CH-37B, CH-47A, UH-1B, UH-1D aircrafts.

CHAPTER 1

INTRODUCTION

Section I. GENERAL

1-1. Scope of Manual

This manual describes Maintenance Kit, Electronic Equipment MK-722/URC (fig. 1-1) and covers its operation and organizational maintenance. The maintenance includes preventive maintenance checks and services, cleaning, and inspection of the equipment.

1-2. Index of Publications

Refer to the latest issue of DA Pamphlet 310-4 to determine whether there are new editions, changes, or additional publications pertaining to the equipment. Department of the Army Pamphlet No. 310-4 is an index of current technical manuals, technical bulletins, supply manuals (types 4, 6, 7, 8, and 9), supply catalogs (type CL), supply bulletins, lubrication orders, and modification work orders that are available through publications supply channels. The index lists the individual parts (-10, -20, -35P, etc) and the latest changes to and revisions of each equipment publication.

1-3. Forms and Records

a. Reports of Maintenance and Unsatisfac-

tory Equipment. Use equipment forms and records in accordance with instructions in TM 38-750.

b. Report of Damaged or Improper Shipment. Fill out and forward DD Form 6 (Report of Damaged or Improper Shipment), as prescribed in AR 700-58, NAVSANDA Publication 378 (Navy), and AFR 71-4 (Air Force).

c. Reporting Equipment Manual Improvements. The direct reporting, by the individual user, of errors, omissions, and recommendations for improving this equipment manual is authorized and encouraged. DA Form 2028 will be used for reporting these improvements. This form may be completed by the use of pencil, pen, or typewriter. DA Form 2028 will be completed in triplicate and forwarded by the individual using the manual. The original and one copy will be forwarded direct to: Commanding General, U. S. Army Electronics Command, ATTN: AMSEL-MR-MA, Fort Monmouth, New Jersey 07703. One information copy will be furnished to the individual's immediate supervisor (officer, noncommissioned officer, supervisor, etc).

Section II. DESCRIPTION AND DATA

1-4. Purpose and Use

a. Purpose. Maintenance Kit, Electronic Equipment MK-722/URC (fig. 1-1) (Collins type maintenance kit 678Y-1, function test set 6782-1, and a transit case, which together are designated as a 678Y-3) provides a transportable means of servicing and aligning the modules of Receiver-Transmitter, Radio RT-698/ARC-102 (Collins type 618T-3) by means of module extenders. The module extenders permit the

modules to be operating while they are extended for convenient access and troubleshooting. Test Set, Radio TS-1956/URC (6782-1) is included as part of Maintenance Kit, Electronic Equipment MK-722/URC and acts as an accurate voltage comparator to set critical voltages in the RT-698/ARC-102. It is also used as a variable voltage source with three different source impedances for test purposes.

b. Use. The MK-722/URC is used for bench testing the RT-698/ARC-102.

1-5. Technical Characteristics

a. General

Ambient temperature range:

Operating0° C to 50° C.

Nonoperating0° C to 50° C.

Ambient humidity range ..Prevailing laboratory or repair station environmental conditions.

Altitude Prevailing laboratory or repair station environmental conditions.

Weight30 pounds.

b. TestSet, Radio TS-1956/URC.

Power requirements115 volts, 400 cps, singlephase, at approximately 0.08 amp.

1-6. Table of Components

Note: This listing is based on the original shipment by the contractor on Order No. FR 11-022-C-4-26699(E). For the current official listing of components of individual models, see the basic issue items list (appx III).

Quantity	Component	Figure No.	Dimensions (in.)			Unit weight (lb)
			Height	Depth	Width	
1	Extender, Module MX-4887/URC	1-3	13	8-1/2	12-23/32	0.936
1	Extender, Module MX-4888/URC	1-3	5-15/16	6-15/16	2-15/16	0.688
1	Extender, Module MX-4889/URC	1-3	6-15/16	4-1/4	1-1/2	0.688
1	Extender, Module MX-4890/URC	1-3	4-1/4	6-15/16	1-7/16	0.688
1	Extender, Module MX-4891/URC	1-3	7-5/16	4-9/16	2-15/16	0.688
1	Extender, Module MX-4892/URC	1-3	4-1/16	7-5/16	2-15/16	0.688
1	Extender, Module MX-4893/URC	1-3	6-15/16	4-5/16	1-7/16	0.3115
1	Extender, Module MX-4894/URC	1-3	5-7/8	3	2-7/16	0.375
1	Extender, Module MX-4895/URC	1-3	6-15/16	5-15/16	2-15/16	0.625
1	Voltage Divider TS-1954/URC	1-6	3-1/8	1	15/16	0.063
1	Voltage Divider TS-1955/URC	1-6	3-1/8	1	15/16	0.063
1	Dummy Load, Electrical DA-340/URC	20, 1-6	3	1-5/16	1-1/16	0.125
1	Detector, Radio Frequency DT-278/URC	1-6	2-5/16	1	15/16	0.0625
1	Cable Assembly, Radio Frequency CG-2549A/U (4 ft, 4 in.)	1-4				0.2
1	Cable Assembly, Radio Frequency CG-3126/U (4 ft, 4-1/2 in.)	1-4				0.2
1	Attenuator, Fixed CN-2730/URC	1-6	3-1/8	1	15/16	0.0625
1	Adapter, Connector UG-274B/U	1-4				0.05
1	Adapter, Connector UG-914/U	1-4				0.06
1	Adapter, Connector UG-491B/U	1-4				0.06
1	Maintenance Fixture, Radio Set MT-3039/URC	1-5	21-3/4	10-9/16	2-3/16	2.0
6	Cable Assembly, Radio Frequency CG-2730/U (4 in.)	1-4				0.0625
1	Test Set, Radio TS-1956/URC	1-1	8-3/4	5-1/2	9-1/8	5.0
1	Cable Assembly, Power Electrical CX-9009/URC (6 ft, 0.0 in.)	1-4				0.312
1	Lead, Test CX-9010/URC (2 ft)	1-4				0.03
1	Lead, Test CX-9011/URC (2 ft)	1-4				0.03
1	Lead, Test CX-9012/URC (2 ft)	1-4				0.03
1	Lead, Test CX-9013/URC (2 ft)	1-4				0.03
1	Lead, Test CX-9014/URC (2 ft)	1-4				0.03
1	Lead, Test CX-9015/URC (2 ft)	1-4				0.03
1	Case, Maintenance Kit CY-4066/URC	1-1	13-7/32	18-7/8	32-25/32	13.0
1	Cable Assembly, Radio Frequency CG-2727/U (5 ft, 0.0 in.)	1-4				0.2
1	Frame, autopositioner	1, 1-6				0.125
1	Adapter, tube, 9-pin	1-6				0.06
1	Adapter, tube, 7-pin	1-6				0.06

Quantity	Component	Figure No.	Dimensions (hr.)			Unit weight (lb)
			Height	Depth	Width	
1	Alignment tool No. 1	11, 1-6				0.02
1	Alignment tool No. 2	12, 1-6				0.02
1	Tuning tool	13, 1-6				0.02
1	Test probe No. 1	7, 1-6				0.0625
1	Test probe No. 2	8, 1-6				0.0625
1	Test probe No. 3	9, 1-6				0.05
1	Pa tube extractor	19, 1-6				0.02
2	Plug, banana, shielded-cap	24, 1-6				0.0625
1	Wrench, Bristo, No. 8	16, 1-6				0.02
1	Wrench, Bristo, No. 4	15, 1-6				0.02
1	Wrench, Bristo, No. 8 (with handle)	18, 1-6				0.0625
1	Screwdriver, Phillip's, No. 2	10, 1-6				0.25
3	Screw, machine, 4-40 by ¼	1-6				0.01
1	Dial, Scale	1-6				0.02
2	Setscrew, 4-40	1-6				0.01
1	Pointer	1-6				0.001
1	Module puller	5, 1-6				0.15

1-7. Common Names

Nomenclature	Common name	Nomenclature	Common name
Maintenance Kit, Electronic Equipment MK-722/URC	Maintenance kit	Adapter, Connector UG-914/U	Adapter A18
Extender, Module MX4887/URC	Rf translator module extender	Adapter, Connector UG-491 B/U	Adapter A19
Extender, Module MX4888/URC	Rf oscillator module extender	Maintenance Fixture, Radio Set MT-3039/URC	Radio test fixture
Extender, Module MX4889/URC	Mc frequency stabilizer module extender	Cable Assembly, Radio Frequency CG-2730/U	Cable WS
Extender, Module MX-4890/URC	Frequency divider module extender	Test Set, Radio, TS-1956/URC	Function test set
Extender, Module MX-4891/URC	Am.-audio amplifier module extender	Cable Assembly, Power Electrical CX-9009/URC	Power cable
Extender, Module MX-4892/URC	It. translator module extender	Lead, Test CX-9010/URC	Test lead W1
Extender, Module MX-4893/URC	Electronic control amplifier module extender	I.cad, Test CX-9011/URC	Test lead W2
Extender, Module MX-4894/URC	Low-voltage power supply module extender	I.cad, Test CX-9012/URC	Test lead W3
Extender, Module MX4895/URC	Kc frequency stabilizer module extender	Lead, Test CX-9013/URC	Test lead W4
Voltage Divider TS-1954/URC	Capacity divider, 2-8 mc	Lead, Test CX-9014/URC	Test lead W5
Voltage Divider TS-1955/URC	Capacity divider, 8-30 mc	Lead, Test CX-9015/URC	Test lead W6
Dummy Load, Electrical DA-340/URC	Rf translator load	Case, Maintenance Kit CY-4066/URC	Transit case
Detector, Radio Frequency DT-278/URC	Neutralizing detector	Cable Assembly, Radio Frequency CG-2727/U	Cable W7
Attenuator, Fixed CN-2730/URC	Generator load	Cable Assembly, Radio Frequency CG-3126/U	Cable W9
Adaptor, Connector UG-274B/U	Adapter A17	Cable Assembly, Radio Frequency CG-2549A/U	Cable W 10
		Receiver-Transmitter, Radio RT-698/ARC-102	Receiver-transmitter

1-8. Description of Test Set, Radio TS-1956/URC

The function test set (fig. 1-2) is removable

from the transit case and is used to set critical voltages in the receiver-transmitter. All test connectors, switches, operating controls, and

the function meter are on the front panel. The alternating current (ac) power connector is on the side panel and the handle is on the top.



Figure 1-2. Function test set.

1-9. Description of Minor Components

a. *Transit Case (fig. 1-1).* The transit case is of molded, reinforced, fiberglass construction with aluminum framework and hardware. It provides a dustproof, portable enclosure for the equipment, with an air relief valve (not shown) for airborne transportation. The transit case is composed of two parts. One half houses the function test set, module extenders, and the radio test fixture. The other half contains a closed compartment. When the door to this half is opened, access is provided to test cables, tools, adapters, loads, and other small parts. The two

halves are fastened together by four twistlock clamps.

b. *Module Extenders (fig. 1-3).* The module extenders are constructed of aluminum, in the shape of the module they replace. They permit the modules to be extended outside the receiver-transmitter chassis so they may be worked on while still being electrically and mechanically connected to the receiver-transmitter. Test points on the module extenders are connected to various pins on the module plugs. These test points facilitate the measurement of significant module voltages and signals. Nine module ex-

tenders are included, one for each module in the receiver-transmitter, except high-voltage power

supply module A8 and power amplifier module A11.

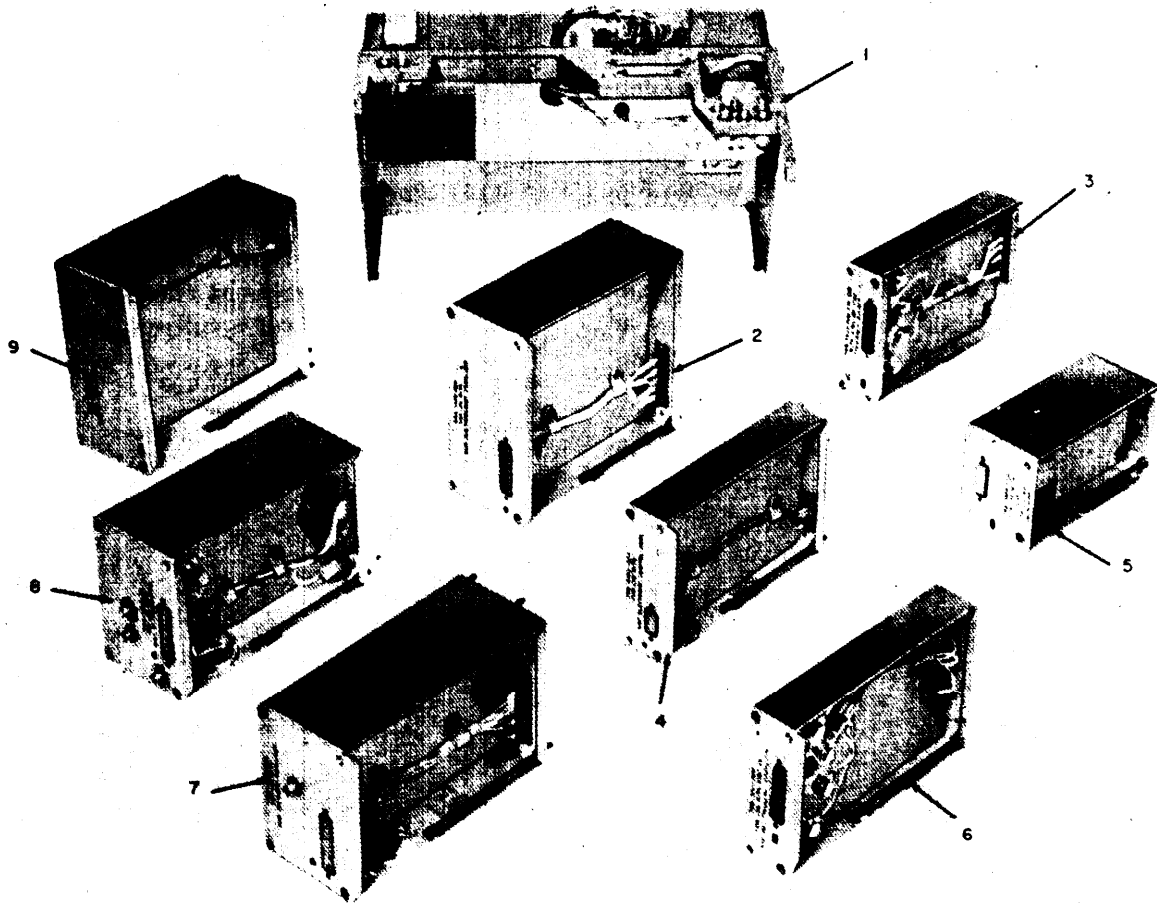

TM6625-623-12-4

- 1 Rf translator module extender
- 2 Kc frequency stabilizer module extender
- 3 Frequency divider module extender
- 4 Electronic control amplifier module extender
- 5 Low-voltage power supply module extender

- 6 Mc frequency stabilizer module extender
- 7 Am.-audio amplifier module extender
- 8 If. translator module extender
- 9 Rf oscillator module extender

Figure 1-3. Module extenders.

c. *Cables, Test Leads, and Adapters* (fig. 1-4). Five cables, six test leads and three adapters are provided as components of the maintenance kit. Each cable is identified by a metal band with the short nomenclature stamped on it. Following is a description of the cables, test leads, and adapters:

- (1) *Test lead W1*. Test lead W1 is a single-conductor, rubber-covered cable, 2 feet long, with an orange jack tip at each end.

- (2) *Test lead W2*. Test lead W2 is a single-conductor, rubber-covered cable, 2 feet long, with a white jack tip at each end.
- (3) *Test lead W3*. Test lead W3 is a single-conductor, rubber-covered cable, 2 feet long, with a brown jack tip at each end.
- (4) *Test lead W4*. Test lead W4 is a single-conductor, rubber-covered cable, 2 feet long, with a red jack tip at each end.
- (5) *Test lead W5*. Test lead W5 is a single-

- conductor, rubber-covered cable, 2 feet long, with a yellow jack tip at each end.
- (6) Test lead W6. Test lead W6 is a single-conductor, rubber-covered cable, 2 feet long, with a jack tip at one end and a sleeve and clip on the other end.
- (7) Cable W7. Cable W7 is a coaxial, vinyl-covered cable, 5 feet long, with a male BNC connector on each end.
- (8) Cable W8. Cable W8 is a coaxial jumper cable, 1-3/4 inches long, with a male coaxial connector at each end.
- (9) Cable W9. Cable W9 is a coaxial, vinyl-covered cable, 4 feet long, with a male BNC connector on one end and a microphone jack tip on the other end.
- (10) Cable W10. Cable W10 is a coaxial, vinyl-covered cable, 4 feet long, with a male BNC connector on one end and a telephone plug on the other end.
- (11) Adapter A17. Adapter A17 is a BNC-type, T-adapter.
- (12) Adapter A18. Adapter A18 is a BNC-type, female straight adapter.
- (13) Adapter A19. Adapter A19 is a BNC-type, male straight adapter.
- (14) Power cable. The power cable is a two-conductor, rubber-covered cable, 6 feet long, with a two-prong twistlock male connector at one end and a mating female connector on the other end.

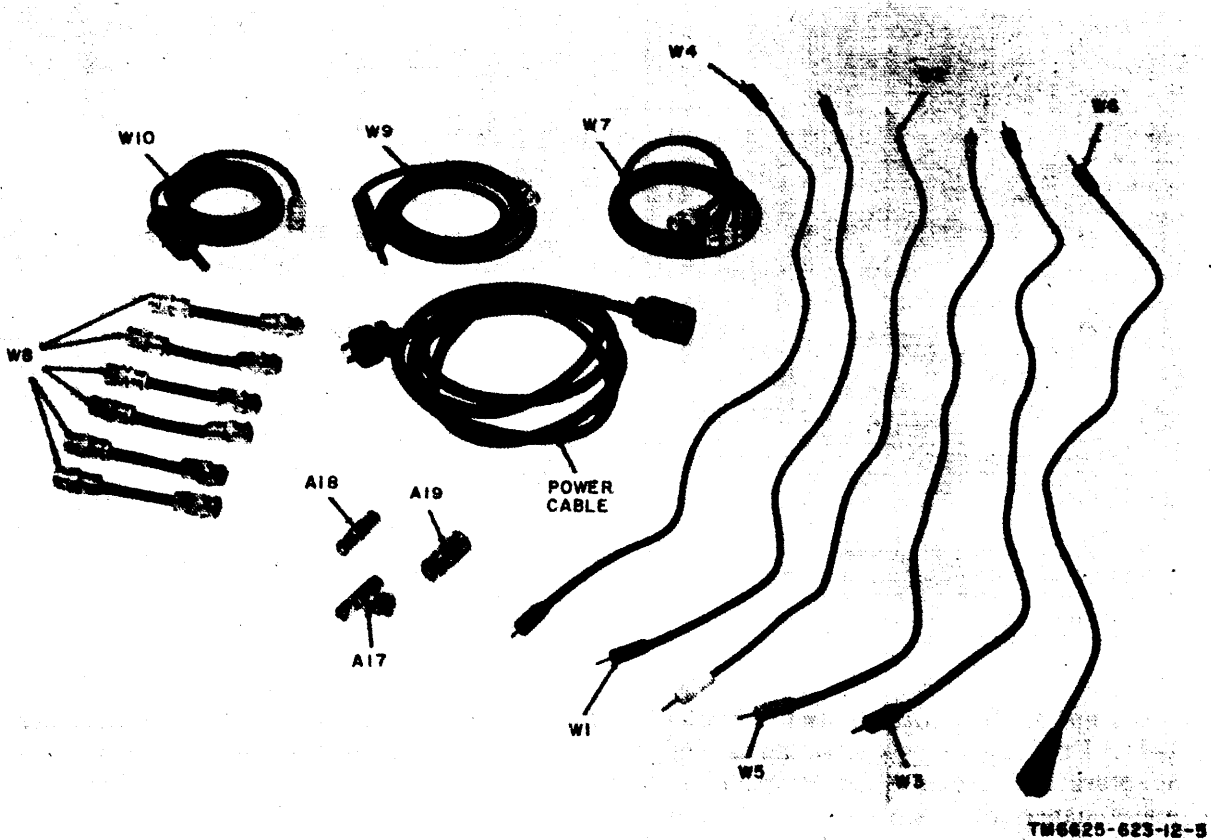
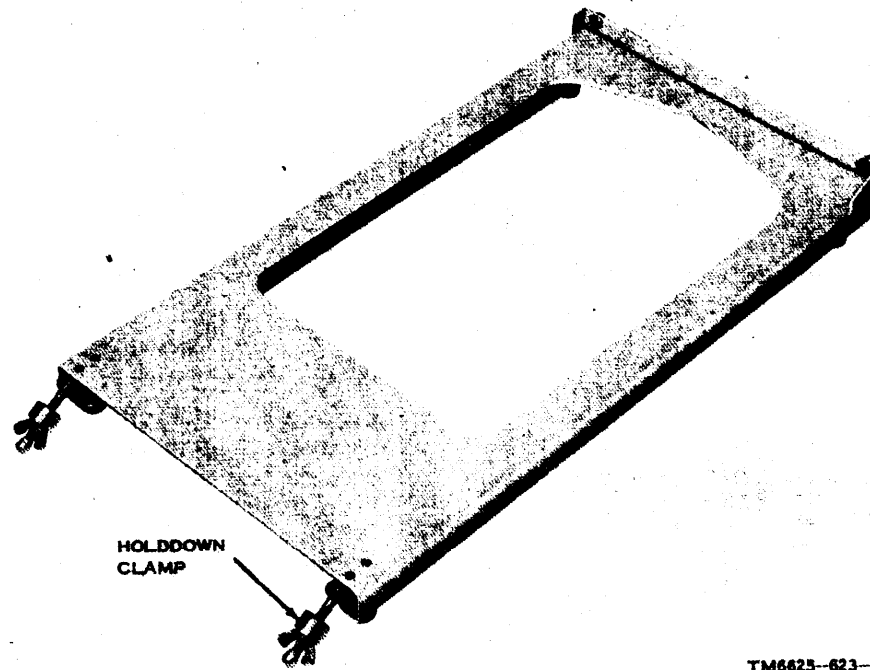

Figure 1-4. Cable, test leads, and adapters.

d. Radio Test Fixture (fig. 1-5). The radio test fixture contains two holddown clamps. It is used as a substitute for the aircraft shock

mount to hold the receiver-transmitter while it is being tested on the bench.



TM6625-623-12-6

Figure 1-5. Radio test fixture.

e. Autopositioner Alignment Aids (fig. 1-6). The autopositioner frame, dial, pointer, and three machine screws are used for alignment and testing the autopositioner in the receiver-transmitter.

f. Capacity Dividers (fig. 1-6). The 2-8 megacycle (mc) and 8-30 mc capacity dividers are used as voltage dividers in the indicated frequency ranges.

g. Rf Translator Load (fig. 1-6). The radio-frequency (rf) translator load is used as a

dummy load when testing the rf translator module of the receiver-transmitter.

h. Generator Load (fig. 22, 1-6). The generator load is used as an impedance matching device for the high-frequency (hf) signal generator.

i. Detector, 2-30 Mc (fig. 21, 1-6). The 2-30 mc detector is used to transmit noise measurements.

j. Neutralizing Detector (fig. 14, 1-6). The neutralizing detector is used in driver and feedback neutralizing adjustments.

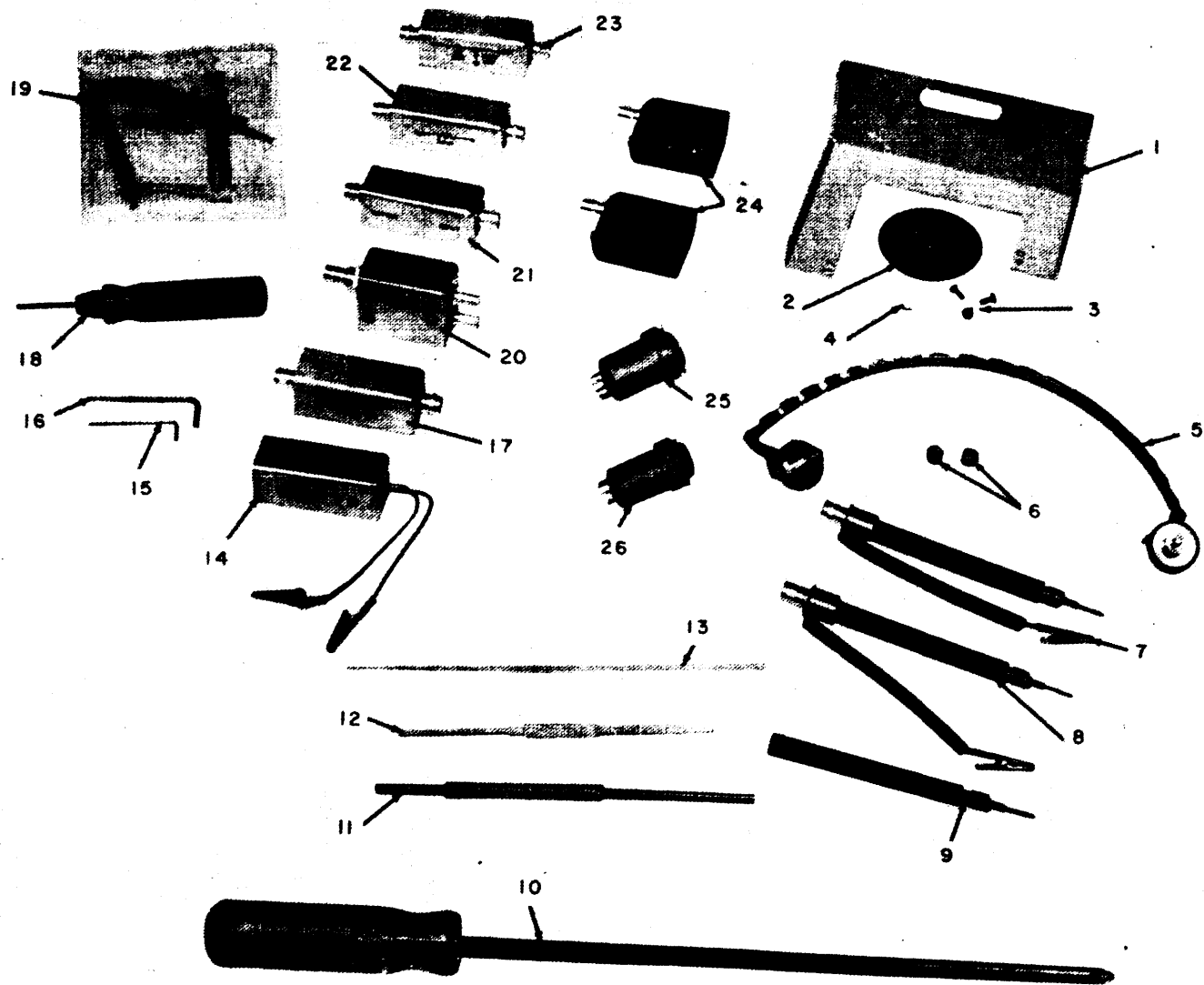

TM6625-623-12-7

Figure 1-6. Small items.

- | | |
|--|---|
| 1 Autopositioner frame | 14 Neutralizing detector |
| 2 Dial | 15 Bristo wrench No. 4 |
| 3 Machine screws, 4-40 x $\frac{1}{4}$ (3) | 16 Bristo wrench No. 8 |
| 4 Pointer | 17 Capacity divider, 8-30 mc |
| 5 Module puller | 18 Bristo wrench No. 8 (with handle) |
| 6 Setscrews, 4-40 (2) | 19 PA tube extractor |
| 7 Test probe No. 1 | 20 Rf translator load |
| 8 Test probe No. 2 | 21 Detector, 2-30 mc |
| 9 Test probe No. 3 | 22 Generator load |
| 10 No. 2 Phillip's screwdriver | 23 Capacity divider, 2-8 mc |
| 11 Alignment tool No. 1 | 24 Shielded-cap, double banana plug (2) |
| 12 Alignment tool No. 2 | 25 Tube extender, 9-pin |
| 13 Tuning tool | 26 Tube extender, 7-pin |

Figure 1-6. Small items.

CHAPTER 2

OPERATION

Section I. SERVICE UPON RECEIPT OF EQUIPMENT

2-1. Unpacking

a. Packaging Data. All components of the maintenance kit are contained in the transit case. When packed for shipment, the air vent on the transit case is opened, find the maintenance kit is placed on four polystyrene corner blocks in the four bottom corners of a tri-wall fiber-board box. Four more corner blocks are placed on the top four corners of the maintenance kit. The box is then closed and taped shut. The box is 17-½ by 22-¼ by 26 inches; the corner blocks are 6 by 6 by 6 inches with cutouts of 4 by 4 by 4 inches; the total weight is 50 pounds; and the volume is 8.1 cubic feet. A typical shipping box and its contents are shown in figure 2-1.

b. Removing Contents.

- (1) Use a knife to cut the tape on the box. Open the four flaps.
- (2) Remove the four corner blocks from the top of the box. Remove the maintenance kit from the box.
- (3) Disengage the four twistlock clamps and open the transit case.
- (4) Unlock the access door by sliding the

two slidelock fasteners. Lift the door open.

2-2. Checking Unpacked Equipment

a. Inspect the equipment for damage incurred during shipment. If the equipment has been damaged, refer to paragraph 1-3b.

b. Check the equipment against the packing list. When no packing list accompanies the equipment, check the equipment against the list of equipment supplied (para 1-6) and report any overages or shortages on DD Form 6 (para 1-3 b).

Note: Shortages of minor assemblies or subassemblies, such as lamps or fuses, that do not affect the proper functioning of the equipment should not prevent use of the equipment.

c. If the equipment has been used or reconditioned, see whether it has been changed by a modification work order (MWO). If the equipment has been modified, the MWO number will appear on the front panel near the nomenclature plate. Check to see whether the MWO number and appropriate notations concerning the modification have been entered in this manual.

Note: Current MWO'S applicable to the equipment are listed in DA Pamphlet 310-4.

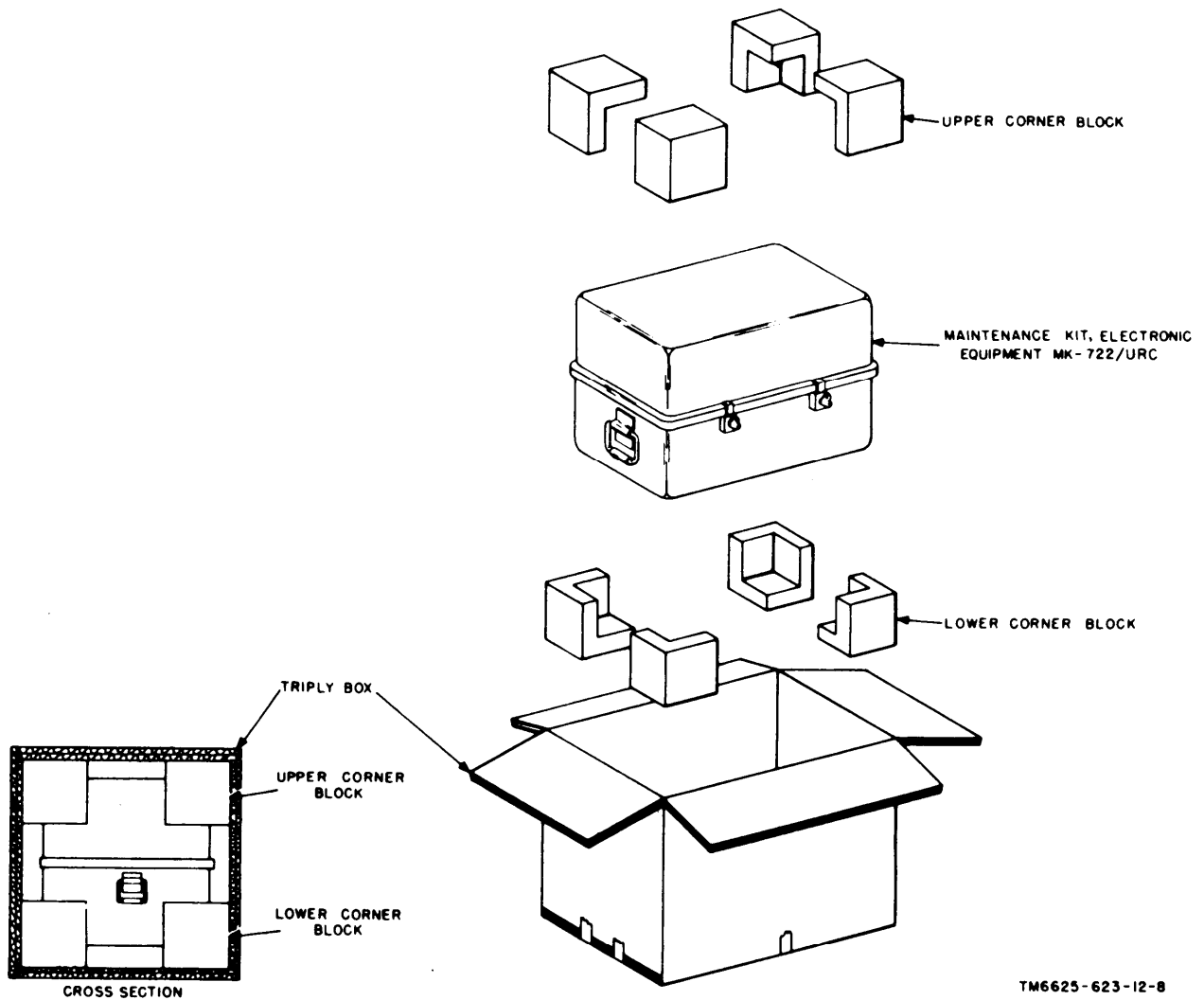

Figure 2-1. Typical packaging.

TM6625-623-12-8

Section II. OPERATING INSTRUCTIONS

2-3. Controls, Indicators, and Connectors (fig. 2-2)

The following chart lists the function test set controls, indicators, and connectors and indicates their functions.

Control, indicator, or connector	Function
FUNCTION METER (null meter)	Indicates differences between junction test set reference voltages and signal voltages being checked.
FUNCTION SELECTOR switch (nine-position rotary)	Selects proper test set function for circuit being checked or calibrated.
<p style="text-align: center;"><i>Switch position</i></p> SET LEVEL Caution: Do not use the X10 METER SENSITIVITY switch or meter may be damaged.	<p style="text-align: center;"><i>Action</i></p> Provides connection from LEVEL SET R1 control to set reference level of FUNCTION METER.

Control, indicator, or connector	Function						
	OFF-SET ADJUST Connects input at J1-KC STAB jack through OFF-SET ADJUST R2 control to FUNCTION METER.						
	70K-5 VFO BIAS Connects inputs at J1-KC STAB jack and J3-KC STAB jack to FUNCTION METER.						
	70K-3 VFO BIAS Connects inputs at J1-KC STAB jack and J3-KC STAB jack to FUNCTION METER.						
	10KC CONTROL BIAS (+20V) Connects input at J4-KC STAB jack to FUNCTION METER.						
	+18V Connects input at J2-FREQ DIVIDER to FUNCTION METER.						
	TGC OVERRIDE Connects inputs at J2-FREQ DIVIDER and J2-IF TRANS jack through TGC AND CAPTURE RANGE R3 control to FUNCTION METER.						
	70K-5 CAPTURE RANGE Connects inputs at J2-FREQ DIVIDER and J3-KC-STAB jacks through TGC & CAPTURE RANGE R3 control to FUNCTION METER.						
	70K-3 CAPTURE RANGE Connects inputs at J2-FREQ DIVIDER and J1-KC STAB jacks through TGC & CAPTURE RANGE R3 control to FUNCTION METER.						
X10 METER SENSITIVITY switch (pushbutton)	Provides for fine meter reading.						
	<table border="0" style="width: 100%;"> <tr> <td style="text-align: center;"><i>Switch position</i></td> <td style="text-align: center;"><i>Action</i></td> </tr> <tr> <td>Normal</td> <td>Does not affect meter reading.</td> </tr> <tr> <td>Depressed</td> <td>Increases meter sensitivity by a factor of 10.</td> </tr> </table>	<i>Switch position</i>	<i>Action</i>	Normal	Does not affect meter reading.	Depressed	Increases meter sensitivity by a factor of 10.
<i>Switch position</i>	<i>Action</i>						
Normal	Does not affect meter reading.						
Depressed	Increases meter sensitivity by a factor of 10.						
TGC & CAPTURE RANGE R3 control	Overrides the receiver-transmitter gain control, and provides a variable bias to the voltage-controlled vfo.						
OFF-SET ADJUST R2 control	Adjusts FUNCTION METER for null with J1-KC STAB jack connected to the kilocycle-frequency stabilizer module.						
LEVEL SET R1 control	Adjusts FUNCTION METER for full-scale reading.						
115V AC pilot light	Indicates power on when illuminated.						
ON-OFF switch (two-position toggle)	Power switch.						
	<table border="0" style="width: 100%;"> <tr> <td style="text-align: center;"><i>Switch position</i></td> <td style="text-align: center;"><i>Action</i></td> </tr> <tr> <td>ON</td> <td>115-volt, 400-cps power is connected.</td> </tr> <tr> <td>OFF</td> <td>115-volt, 400-cps power is disconnected and a protective short is placed across FUNCTION METER.</td> </tr> </table>	<i>Switch position</i>	<i>Action</i>	ON	115-volt, 400-cps power is connected.	OFF	115-volt, 400-cps power is disconnected and a protective short is placed across FUNCTION METER.
<i>Switch position</i>	<i>Action</i>						
ON	115-volt, 400-cps power is connected.						
OFF	115-volt, 400-cps power is disconnected and a protective short is placed across FUNCTION METER.						
J2-IF TRANS jack	Provides electrical connections to transmitter gain control (tgc) circuit in the if translator module of the receiver-transmitter.						
J2-FREQ DIVIDER jack	Provides electrical connection to +18 vdc from the frequency divider module of the receiver-transmitter.						
J3-KC STAB jack	Provides electrical connection to function test set from kc frequency stabilizer module of the receiver-transmitter when making vfo bias adjustments.						
J1-KC STAB jack	Provides electrical connection to function test set from kc frequency stabilizer module of the receiver-transmitter when making vfo bias adjustments.						
J4-KC STAB jack	Provides electrical connection to function test set from kc frequency stabilizer module of the receiver-transmitter when making keyed oscillator adjustment.						
GRND jack	Provides connection from function test set ground to receiver-transmitter ground.						
CALIBRATE WITH 10.000V (two jacks)	Provides electrical connection to function test set from differential vtvm for calibration purposes.						
R4 potentiometer	Calibrates 10.000 volts.						
AUDIO OUT jack (BNC connector)	Provides audio output connection from the function test set to the MIKE jack of the TS-1949/URM-157.						

Control, indicator, or connector	Function
TEST POINT jack	Provides for measuring audio output from AUDIO OUT jack.
AUDIO IN NO. 1 and NO. 2 jack (2-BNC connectors)	Provide electrical connection to function test set from audio oscillator.
Ac power connector (side panel)	Provides connection to 115-volt, 400-cps ac from 115-v, 400 CPS OUT jack on the TS-1949/URM-157.

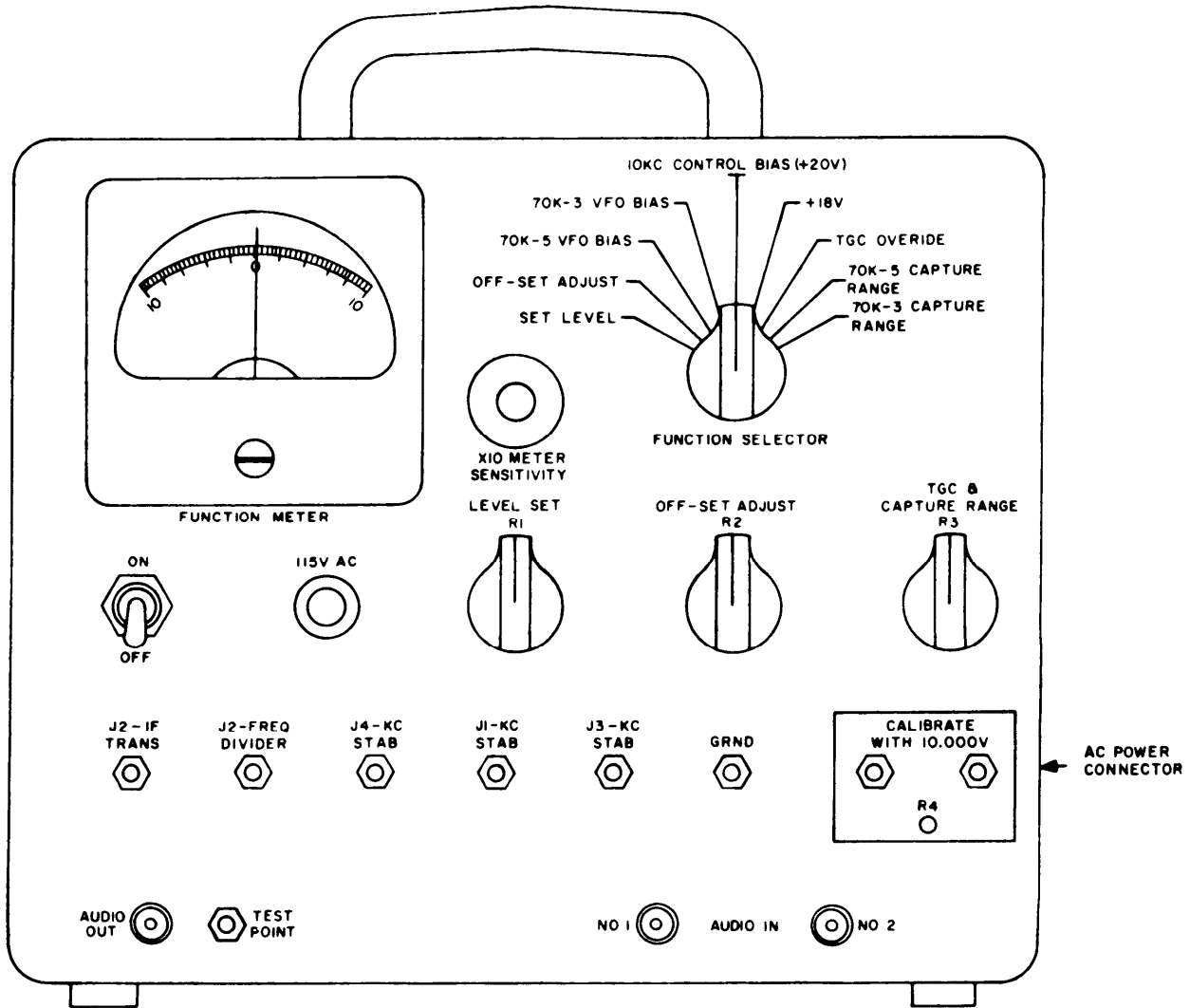

TM6625-623-12-9

Figure 2-2. Function test set, controls, indicators, and connectors.

2-4. Bench Test Procedures

To perform bench troubleshooting of the receiver-transmitter, perform the preliminary starting procedures in paragraph 2-5 and refer to TM 11-5821-248-35, for operating and troubleshooting procedures.

2-5. Preliminary Starting Procedure for Function Test Set

a. Control Settings. Set the function test set ON-OFF switch to OFF and FUNCTION SELECTOR switch to SET LEVEL.

b. Bench Test Connections. Figure 2-3 shows

typical bench test setup connections for testing the receiver-transmitter with the function test set and the TS-1949/URM-157 (test unit).

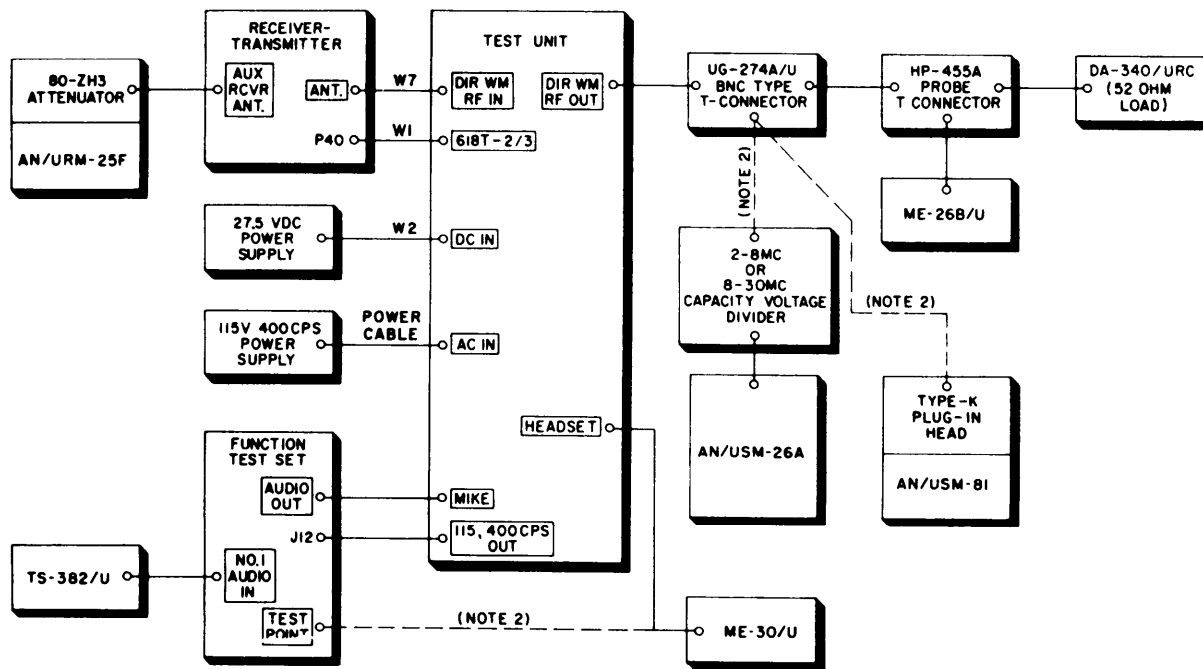

- NOTES:
 1. [] INDICATES EQUIPMENT MARKINGS.
 2. - - DENOTES ALTERNATE CONNECTION.

TM6625-622-12-10

Figure 2-3. Typical bench test setup diagram.

2-6. Stopping Procedures for Function Test Set

a. Set the ON-OFF switch to OFF.

b. Disconnect all cables from the function test set.

CHAPTER 3

MAINTENANCE INSTRUCTIONS

Note: The operator will perform operator and organizational maintenance.

3-1. Scope of Maintenance

The maintenance duties assigned to the operator are listed below, together with a reference to the paragraphs covering the specific maintenance functions. The paragraph includes instructions for performing preventive and corrective maintenance. No tools or materials other than those listed in paragraph 3-2 are required.

- a. Daily preventive maintenance checks and services (para 3-4).
- b. Cleaning (para 3-6).
- c. Monthly preventive maintenance checks and services (para 3-7).
- d. Preservation (para 3-9).
- e. Quarterly preventive maintenance checks and services (para 3-10).

3-2. Tools and Materials Required for Maintenance

- a. Phillip's screwdriver.
- b. Blade screwdriver.
- c. Lint-free cloth.
- d. Sandpaper, extra fine #000.
- e. Small, soft-bristled brush.
- f. Rubber electrician's tape.
- g. Materials for repainting.

3-3. Preventive Maintenance

Preventive maintenance is systematic care, servicing, and inspection of equipment to prevent the occurrence of trouble, to reduce downtime, and to assure that the equipment is serviceable.

- a. *Systematic Care.* The procedures given in

paragraphs 3-4 through 3-11 cover routine systematic care and cleaning essential to proper upkeep and operation of the equipment.

- b. *Preventive Maintenance Checks and Services.* The preventive maintenance checks and service charts (para 3-5, 3-8, and 3-11) outline functions to be performed at specific intervals. These checks and services maintain Army electronic equipment in good general (physical) condition and in good operating condition. To assist operators in maintaining serviceability, the charts indicate what to check, how to check, and the normal conditions; the *Reference* column lists the paragraphs or manuals that contain supplementary information. If the defect cannot be remedied by performing the corrective action indicated, higher category of maintenance or repair is required. Records and reports of these checks and services must be made in accordance with the requirements set forth in TM 38-750.

3-4. Daily Preventive Maintenance Checks and Services

Preventive maintenance checks and services of the maintenance kit are required daily. A daily period is defined as 8 hours of equipment operation. Paragraph 3-5 specifies checks and services that must be accomplished daily or under the special conditions listed below.

- a. When the equipment is initially installed.
- b. When the equipment is reinstalled after removal for any reason.
- c. At least once each week if the equipment is maintained in a *standby* condition.

3-5. Daily Preventive Maintenance Checks and Services Chart

Sequence No.	Item	Procedure	Reference
1	Exterior surfaces	Clean the function test set panel and the function meter. Check for broken meter glass.	Para 3-6.
2	Knobs, switches, and lamps	a. During operation, see that the knobs, switches and lamps operate properly. b. Tighten any loose knobs with the proper blade screwdriver.	
3	Operational test	c. If trouble remains, contact higher level of maintenance for repair. During operation, be alert for any unusual operating indications. If any unusual indications occur, remove all power and contact higher level of maintenance for repair.	Para 2-4 through 2-6.

3-6. Cleaning

Inspect the exterior of the function test set, module extenders, and the transit case. The exterior surface should be clean, and free of dirt, grease, and fungus. Perform the following procedures as specified in the daily preventive maintenance checks and services chart.

Caution: Do not press on the meter face when cleaning; the meter may become damaged.

a. Remove all loose foreign materials with a clean, lint-free cloth.

b. Remove grease, fungus, and ground-in dirt with a cloth dampened (not wet) with water and a mild soap.

Caution: Do not use any cleaning solvent on the front panels or where silk screening is used.

c. Remove dust or dirt from the connectors with a soft-bristled brush.

3-7. Monthly Preventive Maintenance Checks and Services

Perform the maintenance functions indicated in the monthly preventive maintenance checks and services chart (para 3-8) once each month in addition to the daily preventive maintenance checks and services (para 3-5). A month is defined as approximately 30 calendar days of 8-hour-per-day operation. Adjustment of the maintenance interval must be made to compensate for unusual operating conditions. Equipment maintained in a standby (ready for immediate operation) condition must have monthly preventive maintenance checks and services performed on it. Equipment in limited storage (requires service before operation) does not require monthly preventive maintenance.

3-8. Monthly Preventive Maintenance Checks and Services Chart

Sequence No.	Item	Procedure	Reference
1	Cables and module extenders	a. Inspect the cables for deterioration and damage, such as cuts, cracks, or frayed insulation. Repair minor damage to insulation by covering the damaged area with rubber electrician's tape. Replace defective cables. b. Inspect the module extenders for damage, such as bent or missing connector pins. Refer to higher level of maintenance for repair.	
2	Connectors, jacks, and screws	a. Hand check these exterior items for looseness. Tighten all loose exterior items. b. See that no screws are loose or missing and tighten all loose screws.	
3	Exterior surfaces	Inspect all exposed metal surfaces for rust and corrosion. Touch up surfaces.	Para 3-9.

3-9. Preservation

Remove rust and corrosion from metal surfaces by highly sanding therewith #000 sandpaper. Brush two thin coats of paint on the bare metal to protect it from further corrosion. Refer to the applicable cleaning and refinishing practices specified in TB Sig 364.

3-10. Quarterly Preventive Maintenance Checks and Services

Perform the maintenance functions indicated in the quarterly preventive maintenance checks and services chart (para 3-11) once each 3

months (quarterly interval) in addition to the daily (para 3-5) a monthly (para 3-8) preventive maintenance checks and services. A quarterly interval is defined as 90 calendar days of 8-hour-per-day operation. All deficiencies or shortcomings will be recorded, and those not corrected during the maintenance service and inspection will be immediately reported to higher level of maintenance by the use of forms and procedures specified by TM 38-750. Equipment with a deficiency that cannot be corrected at the organizational level should be deadlined in accordance with TM 38-750.

3-11. Quarterly Preventive Maintenance Checks and Services Chart

Sequence No.	Item	Procedure	Reference
1	Completeness	See that the maintenance kit is complete.	Appx III.
2	Publications	Check to see that all pertinent publications are available. The technical manuals must be complete and in usable condition without missing pages. All Changes pertinent to the publications must be on hand.	DA PAM 310-4.
3	Modification work orders	Check to see that all URGENT MWO's have been applied and that all NORMAL MWO's have been scheduled.	DA PAM 310-4.

Note: Each 6 months the function test set is to be sent to a higher level of maintenance for calibration.

CHAPTER 4

SHIPMENT, LIMITED STORAGE, AND DEMOLITION TO PREVENT ENEMY USE

Section I. SHIPMENT AND LIMITED STORAGE

4-1. Disassembly of Equipment

Prepare the maintenance kit for shipment and storage as follows:

- a. Disconnect the cables and test leads.
- b. Roll up the cables and test leads and place them in the cable storage space inside the transit case cover.
- c. Place the voltage dividers, adapters, test probes, dummy load, attenuator, neutralizing detector, rf jumpers, and the alignment and maintenance tools in their proper places inside the transit case cover, and close the door.
- d. Place the function test set, module extenders, and radio test fixture in the places for them in the bottom half of transit case.
- e. Place the cover on the lower half of the transit case.
- f. Secure the four twistlock clamps on the sides of the transit case.

4-2. Repackaging for Shipment and Limited Storage

The exact procedure for repackaging depends on the material available and the conditions under which the equipment is to be shipped

(b below) or stored (c below). Adapt the procedures outlined below whenever circumstances permit.

a. *Material Requirements.* The following materials are required for packaging the maintenance kit for shipment. For stock numbers of materials, consult SB 38-100.

Material	Quantity
Tri-ply fiberboard box	17-1/2 x 22-1/2 x 36 inches
Polystyrene blocks	6 x 6 inches, 8 each
Nylon tape	10 feet

Caution: Be sure the air vent on the end of the transit case is open before packaging for air shipment.

b. *Packaging for Shipment.* See paragraph 2-1 for detailed packaging instructions.

c. *Packaging for Limited Storage.* The transit case provides adequate protection for the other components of the maintenance kit during limited storage. The case is corrosive-resistant and is sealed by a rubber gasket which, with the air vent closed, makes the case interior airtight and moistureproof.

Section II. DEMOLITION OF MATERIEL TO PREVENT ENEMY USE

4-3. Authority for Demolition

The demolition procedures in paragraph 4-4 will be used to prevent the enemy from using or salvaging this equipment. Demolition of the equipment will be accomplished only upon the order of the commander.

4-4. Methods of Destruction

The tactical situation and time available will

determine the method to be used when destruction of equipment is ordered. In most cases, it is preferable to demolish completely some portions of the equipment rather than partially destroy all the equipment units.

a. *Smash.* Use sledges, axes, hammers, crow-bars, and any other heavy tools available to smash the interior units of the maintenance kit.

- (1) Use the heaviest tool on hand to smash

the connectors, meter, knobs, dials, and switches.

Note: Heavy tools will effectively destroy the external parts mentioned in (1) above, but the remainder of the exposed surfaces of the equipment are constructed of steel plate; attempts to damage it by smashing will be useless.

- (2) Remove the units from the transit case. With a heavy hammer or bar, smash as many of the exposed parts of the chassis as possible.

b. *Cut.* Use axes, handaxes, machetes, and similar tools to cut cables and wiring. Use a heavy axe or machete to cut the cables. Cut all cords and cables in a number of places.

Warning: Be extremely careful with explosives and incendiary devices. Use these items only when the need is urgent.

c. *Burn.* Burn the technical manuals first. Burn as much of the equipment as is flammable; use gasoline, oil, flamethrowers, and similar ma-

terials. Pour gasoline on the cut cables and internal wiring and ignite it. Use a flamethrower to burn spare parts or pour gasoline on the spares and ignite them. Use incendiary grenades to complete the destruction of the maintenance kit.

d. *Explode.* Use explosives to complete demolition or to cause maximum damage before burning, when time does not permit complete demolition by other means. Powder charges, fragmentation grenades, or incendiary grenades may be used. Incendiary grenades usually are most effective if destruction of small parts and wiring is desired.

- (1) Use a fragmentation grenade to destroy the interior of the maintenance kit. Drop the grenade into the interior of the maintenance kit.

e. *Dispose.* Bury or scatter destroyed parts or throw them into nearby waterways. This is particularly important if 2 number of parts have not been completely destroyed.

APPENDIX 1

REFERENCES

Following is a list of applicable publications available to the organizational repairman of Maintenance Kit, Electronic Equipment MK-722/URC.

DA Pam 310-4

Index of Technical Manuals, Technical Bulletins, supply Manuals (Types 4, 6, 7, 8, and 9), Supply Catalogs (Type CL), Supply Bulletins, Lubrication Orders, and Modification Work Orders.

SB 38-100

Preservation, Packaging, and Packing Materials, Supplies and Equipment Used by the Army.

TB Sig 364

Field Instructions for Painting and Preserving Electronics Command Equipment.

TM 11-5821-248-35

Direct and General Support and Depot Maintenance Manual, Radio Set AN/ARC-102.

TM 11-6625-622-12

Operator and Organizational Maintenance Manual, Test Harness, Radio Set AN/URM-157.

TM 38-750

Army Equipment Record Procedures.

APPENDIX II

MAINTENANCE ALLOCATION

Section I. INTRODUCTION

A2-1. General

a. This appendix assigns maintenance functions to be performed on components, assemblies, and subassemblies by the lowest appropriate maintenance category.

b. Columns in tile maintenance allocation chart are as follows:

- (1) *Part or component.* This column shows only the nomenclature or standard item name. Additional descriptive data are included only where clarification is necessary to identify the component. Components, assemblies, and subassemblies are listed in top-down order. That is, the assemblies which are part of a component are listed immediately below that component, and the subassemblies which are part of an assembly are listed immediately below that assembly. Each generation breakdown (components, assemblies, or subassemblies) is listed in disassembly order or alphabetical order.
- (2) *Maintenance function.* This column indicates the various maintenance functions allocated to the categories.
 - (a) *Service.* To clean, to preserve, and to replenish lubricants.
 - (b) *Adjust.* To regulate periodically to prevent malfunction.
 - (c) *Inspect.* To verify serviceability and to detect incipient electrical or mechanical failure by scrutiny.
 - (d) *Test.* To verify serviceability and to detect incipient electrical or mechanical failure by use of special equipment such as gages, meters, etc.
 - (e) *Replace.* To substitute serviceable components, assemblies, or subassemblies. for unserviceable components, assemblies, or subassemblies.
 - (f) *Repair.* To restore an item to serviceable condition through correction of a specific failure or unserviceable condition. This function includes but is not limited to welding, grinding, riveting, straightening, and replacement of parts other than the trial and error replacement of running spare type items such as fuses, lamps, or electron tubes.
 - (g) *Align.* To adjust two or more components of an electrical system so that their functions are properly synchronized.
 - (h) *Calibrate.* To determine, check, or rectify the graduation of an instrument, weapon, or weapons system, or components of a weapons *system*.
 - (i) *Overhaul.* To restore an item to completely serviceable condition as prescribed by serviceability standards developed and published by heads of technical services. This is accomplished through employment of the technique of "inspect and Repair Only as Necessary" (IR-OAN). Maximum utilization of diagnostic and test equipment is combined with minimum disassembly of the item during the overhaul process.
 - (j) *Rebuild.* To restore an item to a standard as near as possible to original or new condition in appearance, performance, and life ex-

pectancy. This is accomplished through the maintenance technique of complete disassembly of the item, inspection of all parts or components, repair or replacement of worn or unserviceable elements using original manufacturing tolerances and/or specifications and subsequent reassembly of the item.

- (3) *Operator, organization, direct and general support, and depot.* The symbol X indicates the category responsible for performing that particular maintenance operation, but does not necessarily indicate that repair parts will be stocked at that level. Categories higher than those marked by X are authorized to perform the indicated operation.
- (4) *Tools required.* This column indicates codes assigned to each individual tool equipment, test equipment, and maintenance equipment referenced. The grouping of codes in this column of the maintenance allocation chart indicates the tool, test, and maintenance equipment required to perform the maintenance function.

(5) *Remarks.* Entries in this column will be utilized when necessary to clarify any of the data cited in the preceding column.

c. Columns in the allocation of tools for maintenance functions are as follows:

- (1) *Tools required for maintenance functions.* This column lists tools, test, and maintenance equipment required to perform the maintenance functions.
- (2) *Operator, organization, direct and general support, and depot.* The dagger (†) indicates the categories normally allocated the facility.
- (3) *Tool code.* This column lists the tool code assigned.

A2-2. Maintenance by Using Organizations

When this equipment is used by signal services organizations organic to theater headquarters or communication zones to provide theater communications, those maintenance functions allocated up to and including general support are authorized to the organization operating this equipment.

SECTION II. MAINTENANCE ALLOCATION CHART

PART OR COMPONENT	MAINTENANCE FUNCTION	ECHELON					TOOLS REQUIRED	REMARKS
		O	C	O	DS	GS		
MAINTENANCE KIT, ELECTRONIC EQUIPMENT MK-722/URC	service			X				Continuity and Operational Replace fuses, knobs, lamps Including calibration on alignment of test set
	inspect			X				
	test			X			5	
	repair			X			5	
	overhaul					X	1, 2, 3, 4, 6	
ATTENUATOR, FIXED	replace					X	4	
	repair					X	4	
CABLE ASSEMBLIES, RF	service			X			5	Continuity
	test					X	1	
	replace					X	4	
DETECTOR, RF DT-278/ARC-102	inspect			X				
	test					X	1	
	replace					X	4	
DIAL, SCALE	service			X				
	inspect			X				
	replace					X	4	
DUMMY LOAD, ELECTRICAL DA-340/ARC-102	replace					X	4	
	repair					X	4	
	service			X				
EXTENDERS, MODULE MX-4887/ARC-102; MX-4888/ARC-102; MX-4889/ARC-102; MX-4890/ARC-102; MX-4891/ARC-102; MX-4892/ARC-102; MX-4893/ARC-102; MX-4894/ARC-102; MX-4895/ARC-102	inspect			X				
	test					X	1, 2	
	replace					X	4	
	service			X				
MAINTENANCE FIXTURE MT-3039/ARC-102	inspect			X				
	replace			X				
	repair					X	4	
	service			X				
PRODS, TEST NO. 1; No. 2; No. 3	inspect			X				
	replace					X	4	
	repair					X	4	
TEST SET	service			X				Replace fuses, knobs, lamps Including calibration or alignment of reference voltages.
	inspect			X				
	repair			X			5	
	overhaul					X	1, 2, 3, 4, 6	
VOLTAGE DIVIDER TS-1955/ARC-102	service			X				
	inspect			X				
	test					X	1	
	replace					X	4	
	repair					X	4	

SELMS Form 1151 (Replaces SELMS 004 TF, which is obsolete)
1 Apr 64

MK-722/URC

1

Army-Ft Monmouth, NJ-MON 190-64

SECTION III. ALLOCATION OF TOOLS FOR MAINTENANCE FUNCTIONS

TOOLS REQUIRED FOR MAINTENANCE FUNCTIONS	ECHELON					TOOL CODE	REMARKS
	O	C	O	DS	GS		
MK-722/URC (continued)							
MULTIMETER TS-352/U					+	+	1
MULTIMETER, METER ME-26/U					+	+	2
POWER SUPPLY PP-351/U					+	+	3
TOOL KIT, ELECTRONIC EQUIPMENT TK-100/G					+	+	4
TOOLS AND TEST EQUIPMENT Normally Available to the Repairman-User Because of His Assigned Mission					+		5
VOLTMETER, ELECTRONIC AN/USM-98					+	+	6

APPENDIX III

BASIC ISSUE ITEMS LIST

Section I. INTRODUCTION

A3-1. General

This appendix lists items supplied for initial operation. The list includes tools, parts, and material issued as part of the major end item. The list includes all items authorized for basic operator maintenance of the equipment. End items of equipment are issued on the basis of allowances prescribed in equipment authorization tables and other documents that are a basis for requisitioning.

A3-2. Columns

Columns are as follows:

a. Federal Stock Number. This column lists the 1 1-digit Federal stock number.

b. Designation by Model. Not used.

c. Description. Nomenclature or the standard item name and brief identifying data for each item are listed in this column. When requisitioning, enter the nomenclature and description.

d. Unit of Issue. The unit of issue is each unless otherwise indicated and is the supply term by which the individual item is counted for procurement, storage, requisitioning, allowances, and issue purposes.

e. Expendability. Nonexpendable items are indicated by NX. Expendable items are not annotated.

f. Quantity Authorized. Under "Items Comprising an Operable Equipment," the column lists the quantity of items supplied for the initial operation of the equipment.

g. Illustration. Not used.

SECTION II. FUNCTIONAL PARTS LIST

FEDERAL STOCK NUMBER	DESIGNATION BY MODEL	DESCRIPTION	UNIT OF ISSUE	EXP	QTY AUTH	ILLUSTRATION	
						FIGURE NO.	ITEM NO.
		MAINTENANCE KIT, ELECTRONIC EQUIPMENT MK-722/URC: provides module extenders, adapter cables, and special tools so that adjustments may be performed for the Radio Sets AN/ARC-102 and AN/MRC-95. A complete operational check is provided when used in conjunction w/test harness AN/URM-157; Collins Radio p/n 522-3401.005 (M5AD2-A001)		NX			
ORD THRU AGC		TECHNICAL MANUAL TM 11-6625-623-12			2		
5935-682-1892		ADAPTER, CABLE UG-274B/U:			1		
5935-549-1134		ADAPTER, CONNECTOR UG-491B/U: 1 cont; 2 connector mating ends; MIL type MS35176			1		
5935-280-1454		ADAPTER, CONNECTOR UG-914/U			1		
5935-709-5709		ADAPTER, CONNECTOR: Pomona Elec p/n 1645			2		
5120-288-7786		ALIGNMENT TOOL, ELECTRONIC EQUIPMENT: wrench type; hexagon socket; 5.123 in lg o/a; GC Elec p/n 8606			1		
5120-516-3108		ALIGNMENT TOOL, ELECTRONIC EQUIPMENT: wrench type; slot type; 5.999 in lg o/a; Jaco Prod p/n 024-0309-00; Collins Radio p/n 024-0309-00			1		
5821-019-6317		ATTENUATOR, FIXED CN-1066/URC: 3.125 in lg x 0.937 in wd x 1 in h o/a Collins Radio p/n 548-3522-002		NX	1		
8105-063-5060		BAG, COTTON DUCK: drawstring enclosure; 6 in lg x 4 in wd National Bag Co. p/n 104N4X6			1		
		CABLE ASSEMBLY, RF CG-2549A/U: 4 ft 4 in; plug UG-88E/U on one end; Plug, telephone PR Mallory p/n 75 other end; Collins Radio p/n 548-3489-002 (M5AD2-A019)			1		
6625-964-2630		CABLE ASSEMBLY, RF CG-2727/U: 5 ft			1		
5995-986-7888		CABLE ASSEMBLY, RF CG-2730/U: plug UG-88E/U on ea end; Collins Radio p/n 546-7321-002			6		
		CABLE ASSEMBLY, RF CG-3126/U: 4 ft 4 in; plug UG-88E/U on one end; other end, plug telephone PJ068; Collins Radio 548-3490-002 (M5AD2-A023)			1		

FEDERAL STOCK NUMBER	DESIGNATION BY MODEL	DESCRIPTION	UNIT OF ISSUE	EXP	QTY AUTH	ILLUSTRATION	
						FIGURE NO.	ITEM NO.
		MK-722/URC (continued)					
		CABLE ASSEMBLY, POWER, ELECTRICAL CX-9009/URC: plug, Hubbell p/n 7429 on one end, plug, GE p/n 4725-3 other end; Collins Radio p/n 548-3539-002 (M5AD2-A310)			1		
		CASE, MAINTENANCE KIT CY-4066/URC: provides for storage and transit of maintenance kit, Electronic Equipment MK-722/URC; Skydyne p/n SK625200 (M5AD2-A031)			1		
6625-019-6316		DETECTOR, RADIO FREQUENCY DT-278/URC: used in neutralizing the driver circuits of the RF Translator module; Collins Radio p/n 548-3533-002		NX	1		
5821-081-3957		DIAL, SCALE: 0 to 90 cw; 2 in dia x 0.188 in thk; Collins Radio p/n 548-3530-002			1		
5821-019-6315		DUMMY LOAD, ELECTRICAL DA-340/URC: provides RF translator module w/dummy load for test purposes; Collins Radio #549-0989-003		NX	1		
6625-019-6301		EXTENDER, MODULE MX-4887/URC: extends the RF translator module of the RT-698/ARC-102 for testing; Collins Radio p/n 548-3452-00		NX	1		
6625-019-6311		EXTENDER, MODULE MX-4888/URC: extends the RF oscillator module of the RT-698/ARC-102 for testing; Collins Radio p/n 548-3463-004		NX	1		
6625-019-6303		EXTENDER, MODULE MX-4889/URC: extends frequency stabilizer module of the Receiver-Transmitter, Radio RT-698/ARC-102 for testing; Collins Radio p/n 548-3501-004		NX	1		
6625-019-6304		EXTENDER, MODULE MX-4890/URC: extends frequency divider module of the Receiver-Transmitter, Radio RT-698/ARC-102 for testing; Collins Radio p/n 548-3502-004		NX	1		
6625-019-6310		EXTENDER, MODULE MX-4891/URC: extends the AM/AUDIO module of RT-698/ARC-102 for testing; Collins Radio p/n 548-3461-004		NX	1		
6625-083-7311		EXTENDER, MODULE MX-4892/URC: extends the IF Translator module of RT-698/ARC-102 for testing; Collins Radio p/n 548-3505-00		NX	1		
6625-019-6305		EXTENDER MODULE MX-4893/URC: extends the Amplifier module of RT-698/ARC-102 for testing; Collins Radio p/n 548-3543-004		NX	1		

FEDERAL STOCK NUMBER	DESIGNATION BY MODEL	DESCRIPTION	UNIT OF ISSUE	EXP	QTY AUTH	ILLUSTRATION	
						FIGURE NO.	ITEM NO.
		MK-722/URC (continued)					
6625-019-6306		EXTENDER, MODULE MX-4894/URC: extends the low voltage power supply of RT-698/ARC-102 for testing; Collins Radio p/n 548-3455-004		NX	1		
6625-019-6309		EXTENDER, MODULE MX-4895/URC: extends the frequency stabilizer module of RT-698/ARC-102 for testing; Collins Radio p/n 548-3459-004		NX	1		
5120-763-1262		EXTRACTOR, ELECTRON TUBE: tong type; Eitel-McCullough p/n SK604A			2		
		FRAME, ACTUATOR: al; 5.063 in x 4.000 in x 2.016 in o/a; Collins Radio p/n 548-8014-003 (L4AA54-14)			1		
5120-293-0195		KEY: Bristol Co. p/n S060-4-6CDPL			1		
5120-223-6995		KEY: Bristol Co. p/n S096-8-6CDPL			1		
5120-995-7192		KEY, SOCKET HEAD SCREW: splined type, 6 flutes; 0.940 in dia Bristol Co. Read Ind Instr Div p.n AS096			1		
6625-019-6318		MAINTENANCE FIXTURE, RADIO SET MT-3039/URC: provides facilities for elevating RT-698/ARC-102 during test to allow air to be exhausted from bottom; Collins Radio p/n 549-0990-004		NX	1		
5355-062-0949		POINTER, DIAL: al; 0.687 in lg x 0.250 in wd x 0.485 in h; Collins Radio p/n 549-0974-002			1		
6625-061-3649		PROD, TEST: black plastic handle 3 in lg; 5.300 lg x 0.500 in wd x 0.906 in h o/a Collins Radio p/n 548-3484-002			1		
6625-019-6312		PROD, TEST red plastic 3 in lg; incl capacitor; 6.096 in lg x 0.500 in wd x 0.968 in h o/a; Collins Radio p/n 548-3486-002			1		
6625-061-3648		PROD, TEST: red plastic handle, 3 in lg; cable attached w/jack tip; 4.437 in lg x 0.375 in dia o/a; Collins Radio p/n 548-3499-002			1		
5821-084-0136		PRINTED CIRCUIT KIT: Collins Radio p/n 549-0637-002			1		
5120-975-8165		SCREWDRIVER: American Steel Works of Kansas p/n 1202 with 9 in proj			1		

FEDERAL STOCK NUMBER	DESIGNATION BY MODEL	DESCRIPTION	UNIT OF ISSUE	EXP	QTY AUTH	ILLUSTRATION	
						FIGURE NO.	ITEM NO.
		MK-722/URC (continued)					
6625-893-6606		TEST SET TS-1956/URC: 9.125 in lg x 5.5 in wd x 8.812 in h; Collins Radio p/n 761-4984-001		NX	1		
		LEAD, TEST CX-9010/URC: Provides grounding facilities for the Test Set, Radio TS-1956/URC; Collins Radio Company part No. 549-1005-002 (M5AD2-A332)			1		
		LEAD, TEST CX-9011/URC: provides interconnecting facilities between the Receiver-Transmitter, Radio RT-698/ARC-102 and Test Set, Radio TS-1956/URC; Collins Radio Co. part No. 549-1006-003 (M5AD2-A335)			1		
		LEAD, TEST CX-9012/URC: provides interconnecting facilities between the Receiver-Transmitter, Radio RT-698/ARC-102 and Test Set, Radio TS-1956/URC; Collins Radio Co. part No. 549-1007-003 (M5AD2-A337)			1		
		LEAD, TEST CX-9013/URC: provides interconnecting facilities between Receiver-Transmitter, Radio RT-698/ARC-102 and Test Set, Radio TS-1956/URC; Collins Co. part No. 423-0241-00 (M5AD-A339)			1		
		LEAD, TEST CX-9014/URC: provides interconnecting facilities between the Receiver-Transmitter, Radio RT-698/ARC-102 and Test Set, Radio TS-1956/URC Collins Radio Co. part No. 1009-003 (M5AD2-A341)			1		
		LEAD, TEST CX-9015/URC: provides interconnecting facilities between the Receiver-Transmitter, Radio RT-698/ARC-102 and the Test Set, Radio TS-1956/URC Collins Radio Co. part No. 549-1010-003 (M5AD2-A343)			1		
5120-060-6423		TOOL, TUNING: Collins Radio p/n 547-2796-002			1		
6625-019-6314		VOLTAGE DIVIDER TS-1954/URC: reduces the RF output voltage of the RT-698/ARC-102 from approx 80v to approx 2.5v; Collins Radio p/n 548-3525-002		NX	1		
6625-019-6313		VOLTAGE DIVIDER TS-1955/URC: reduces RF output voltage of RT-698/ARC-102 from approx 80v to approx 2.5v; Collins Radio p/n 548-3528-002		NX	1		

FEDERAL STOCK NUMBER	DESIGNATION BY MODEL	DESCRIPTION	UNIT OF ISSUE	EXP	QTY AUTH	ILLUSTRATION	
						FIGURE NO.	ITEM NO.
		MK-722/URC (continued) RUNNING SPARE ITEMS NO PARTS AUTHORIZED FOR STOCKAGE AT OPERATIO'S LEVEL					

MK-722/URC

By Order of the Secretary of the Army:

Official:

J. C. LAMBERT,
Major General, United States Army,
The Adjutant General.

HAROLD K. JOHNSON,
General, United States Army,
Chief of Staff.

Distribution:

To be distributed in accordance with DA Form 12-36 requirements for Field Maintenance Instructions for CH-47A, CV-2B, CV-7A, UH-1B, UH-1D, U-8F, OV-1A, OV-1B, OV-1C and U-10A Aircraft.

RECOMMENDED CHANGES TO EQUIPMENT TECHNICAL PUBLICATIONS



THEN...JOT DOWN THE DOPE ABOUT IT ON THIS FORM. CAREFULLY TEAR IT OUT, FOLD IT AND DROP IT IN THE MAIL.

SOMETHING WRONG WITH PUBLICATION

FROM: (PRINT YOUR UNIT'S COMPLETE ADDRESS)

DATE SENT

PUBLICATION NUMBER

PUBLICATION DATE

PUBLICATION TITLE

BE EXACT PIN-POINT WHERE IT IS

PAGE NO.

PARA-GRAPH

FIGURE NO.

TABLE NO.

IN THIS SPACE, TELL WHAT IS WRONG AND WHAT SHOULD BE DONE ABOUT IT.

TEAR ALONG PERFORATED LINE

PRINTED NAME, GRADE OR TITLE AND TELEPHONE NUMBER

SIGN HERE

